



**en** *Operator's Manual*

**es** *Manual del Operario*

**fr** *Manuel de l'opérateur*

Model 210000  
Power Built™  
Intek™

Model 310000  
Power Built™  
Intek™

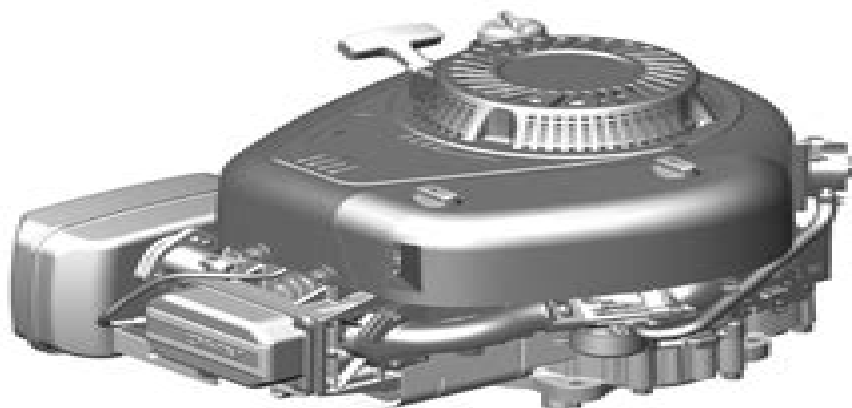

Copyright © Briggs & Stratton Corporation,  
Milwaukee, WI, USA. All rights reserved.  
Briggs & Stratton is a registered trademark  
of Briggs & Stratton Corporation.



Form No. 276344TR1  
Revision: T

English

en

Español

es

Français

fr

# Briggs And Stratton 12000 Service Manual

**LP Steffe**



**Briggs And Stratton 12000 Service Manual:**

## Reviewing **Briggs And Stratton 12000 Service Manual**: Unlocking the Spellbinding Force of Linguistics

In a fast-paced world fueled by information and interconnectivity, the spellbinding force of linguistics has acquired newfound prominence. Its capacity to evoke emotions, stimulate contemplation, and stimulate metamorphosis is truly astonishing. Within the pages of "**Briggs And Stratton 12000 Service Manual**," an enthralling opus penned by a highly acclaimed wordsmith, readers embark on an immersive expedition to unravel the intricate significance of language and its indelible imprint on our lives. Throughout this assessment, we shall delve into the book's central motifs, appraise its distinctive narrative style, and gauge its overarching influence on the minds of its readers.

[https://stats.tinkerine.com/results/virtual-library/HomePages/boeing\\_777\\_aircraft\\_fault\\_isolation\\_manual.pdf](https://stats.tinkerine.com/results/virtual-library/HomePages/boeing_777_aircraft_fault_isolation_manual.pdf)

### **Table of Contents Briggs And Stratton 12000 Service Manual**

1. Understanding the eBook Briggs And Stratton 12000 Service Manual
  - The Rise of Digital Reading Briggs And Stratton 12000 Service Manual
  - Advantages of eBooks Over Traditional Books
2. Identifying Briggs And Stratton 12000 Service Manual
  - Exploring Different Genres
  - Considering Fiction vs. Non-Fiction
  - Determining Your Reading Goals
3. Choosing the Right eBook Platform
  - Popular eBook Platforms
  - Features to Look for in an Briggs And Stratton 12000 Service Manual
  - User-Friendly Interface
4. Exploring eBook Recommendations from Briggs And Stratton 12000 Service Manual
  - Personalized Recommendations
  - Briggs And Stratton 12000 Service Manual User Reviews and Ratings
  - Briggs And Stratton 12000 Service Manual and Bestseller Lists

5. Accessing Briggs And Stratton 12000 Service Manual Free and Paid eBooks
  - Briggs And Stratton 12000 Service Manual Public Domain eBooks
  - Briggs And Stratton 12000 Service Manual eBook Subscription Services
  - Briggs And Stratton 12000 Service Manual Budget-Friendly Options
6. Navigating Briggs And Stratton 12000 Service Manual eBook Formats
  - ePub, PDF, MOBI, and More
  - Briggs And Stratton 12000 Service Manual Compatibility with Devices
  - Briggs And Stratton 12000 Service Manual Enhanced eBook Features
7. Enhancing Your Reading Experience
  - Adjustable Fonts and Text Sizes of Briggs And Stratton 12000 Service Manual
  - Highlighting and Note-Taking Briggs And Stratton 12000 Service Manual
  - Interactive Elements Briggs And Stratton 12000 Service Manual
8. Staying Engaged with Briggs And Stratton 12000 Service Manual
  - Joining Online Reading Communities
  - Participating in Virtual Book Clubs
  - Following Authors and Publishers Briggs And Stratton 12000 Service Manual
9. Balancing eBooks and Physical Books Briggs And Stratton 12000 Service Manual
  - Benefits of a Digital Library
  - Creating a Diverse Reading Collection Briggs And Stratton 12000 Service Manual
10. Overcoming Reading Challenges
  - Dealing with Digital Eye Strain
  - Minimizing Distractions
  - Managing Screen Time
11. Cultivating a Reading Routine Briggs And Stratton 12000 Service Manual
  - Setting Reading Goals Briggs And Stratton 12000 Service Manual
  - Carving Out Dedicated Reading Time
12. Sourcing Reliable Information of Briggs And Stratton 12000 Service Manual
  - Fact-Checking eBook Content of Briggs And Stratton 12000 Service Manual
  - Distinguishing Credible Sources
13. Promoting Lifelong Learning

- Utilizing eBooks for Skill Development
  - Exploring Educational eBooks
14. Embracing eBook Trends
- Integration of Multimedia Elements
  - Interactive and Gamified eBooks

### **Briggs And Stratton 12000 Service Manual Introduction**

Free PDF Books and Manuals for Download: Unlocking Knowledge at Your Fingertips In today's fast-paced digital age, obtaining valuable knowledge has become easier than ever. Thanks to the internet, a vast array of books and manuals are now available for free download in PDF format. Whether you are a student, professional, or simply an avid reader, this treasure trove of downloadable resources offers a wealth of information, conveniently accessible anytime, anywhere. The advent of online libraries and platforms dedicated to sharing knowledge has revolutionized the way we consume information. No longer confined to physical libraries or bookstores, readers can now access an extensive collection of digital books and manuals with just a few clicks. These resources, available in PDF, Microsoft Word, and PowerPoint formats, cater to a wide range of interests, including literature, technology, science, history, and much more. One notable platform where you can explore and download free Briggs And Stratton 12000 Service Manual PDF books and manuals is the internet's largest free library. Hosted online, this catalog compiles a vast assortment of documents, making it a veritable goldmine of knowledge. With its easy-to-use website interface and customizable PDF generator, this platform offers a user-friendly experience, allowing individuals to effortlessly navigate and access the information they seek. The availability of free PDF books and manuals on this platform demonstrates its commitment to democratizing education and empowering individuals with the tools needed to succeed in their chosen fields. It allows anyone, regardless of their background or financial limitations, to expand their horizons and gain insights from experts in various disciplines. One of the most significant advantages of downloading PDF books and manuals lies in their portability. Unlike physical copies, digital books can be stored and carried on a single device, such as a tablet or smartphone, saving valuable space and weight. This convenience makes it possible for readers to have their entire library at their fingertips, whether they are commuting, traveling, or simply enjoying a lazy afternoon at home. Additionally, digital files are easily searchable, enabling readers to locate specific information within seconds. With a few keystrokes, users can search for keywords, topics, or phrases, making research and finding relevant information a breeze. This efficiency saves time and effort, streamlining the learning process and allowing individuals to focus on extracting the information they need. Furthermore, the availability of free PDF books and manuals fosters a culture of continuous learning. By removing financial barriers, more people can access educational resources and pursue lifelong

learning, contributing to personal growth and professional development. This democratization of knowledge promotes intellectual curiosity and empowers individuals to become lifelong learners, promoting progress and innovation in various fields. It is worth noting that while accessing free Briggs And Stratton 12000 Service Manual PDF books and manuals is convenient and cost-effective, it is vital to respect copyright laws and intellectual property rights. Platforms offering free downloads often operate within legal boundaries, ensuring that the materials they provide are either in the public domain or authorized for distribution. By adhering to copyright laws, users can enjoy the benefits of free access to knowledge while supporting the authors and publishers who make these resources available. In conclusion, the availability of Briggs And Stratton 12000 Service Manual free PDF books and manuals for download has revolutionized the way we access and consume knowledge. With just a few clicks, individuals can explore a vast collection of resources across different disciplines, all free of charge. This accessibility empowers individuals to become lifelong learners, contributing to personal growth, professional development, and the advancement of society as a whole. So why not unlock a world of knowledge today? Start exploring the vast sea of free PDF books and manuals waiting to be discovered right at your fingertips.

## **FAQs About Briggs And Stratton 12000 Service Manual Books**

**What is a Briggs And Stratton 12000 Service Manual PDF?** A PDF (Portable Document Format) is a file format developed by Adobe that preserves the layout and formatting of a document, regardless of the software, hardware, or operating system used to view or print it. **How do I create a Briggs And Stratton 12000 Service Manual PDF?** There are several ways to create a PDF: Use software like Adobe Acrobat, Microsoft Word, or Google Docs, which often have built-in PDF creation tools. Print to PDF: Many applications and operating systems have a "Print to PDF" option that allows you to save a document as a PDF file instead of printing it on paper. Online converters: There are various online tools that can convert different file types to PDF. **How do I edit a Briggs And Stratton 12000 Service Manual PDF?** Editing a PDF can be done with software like Adobe Acrobat, which allows direct editing of text, images, and other elements within the PDF. Some free tools, like PDFescape or Smallpdf, also offer basic editing capabilities. **How do I convert a Briggs And Stratton 12000 Service Manual PDF to another file format?** There are multiple ways to convert a PDF to another format: Use online converters like Smallpdf, Zamzar, or Adobe Acrobats export feature to convert PDFs to formats like Word, Excel, JPEG, etc. Software like Adobe Acrobat, Microsoft Word, or other PDF editors may have options to export or save PDFs in different formats. **How do I password-protect a Briggs And Stratton 12000 Service Manual PDF?** Most PDF editing software allows you to add password protection. In Adobe Acrobat, for instance, you can go to "File" -> "Properties" -> "Security" to set a password to restrict access or editing capabilities. Are there any free alternatives to Adobe Acrobat for

working with PDFs? Yes, there are many free alternatives for working with PDFs, such as: LibreOffice: Offers PDF editing features. PDFsam: Allows splitting, merging, and editing PDFs. Foxit Reader: Provides basic PDF viewing and editing capabilities. How do I compress a PDF file? You can use online tools like Smallpdf, ILovePDF, or desktop software like Adobe Acrobat to compress PDF files without significant quality loss. Compression reduces the file size, making it easier to share and download. Can I fill out forms in a PDF file? Yes, most PDF viewers/editors like Adobe Acrobat, Preview (on Mac), or various online tools allow you to fill out forms in PDF files by selecting text fields and entering information. Are there any restrictions when working with PDFs? Some PDFs might have restrictions set by their creator, such as password protection, editing restrictions, or print restrictions. Breaking these restrictions might require specific software or tools, which may or may not be legal depending on the circumstances and local laws.

### **Find Briggs And Stratton 12000 Service Manual :**

**boeing 777 aircraft fault isolation manual**

**bond 11 test papers maths multiple choice pack 2 bond 10 minute tests maths**

*bombardier rotax 400 manual*

bonhoeffer on the christian life from the cross for the world

*bongard maintenance manual deck ovens*

boeken top 10 bibliotheek

bogen multicom 2000 programming manual

**bombardier atv repair manuals**

**bombardier user manual**

bogen multicom 2015 programming manual

boeing flight planning and performance manual

bomag bw141 ad 4 manual

bolens tube frame manual

**bond maths assessment papers 7 8 years**

boeing 737 technical guide chris brady

### **Briggs And Stratton 12000 Service Manual :**

**market leader advanced progress test1 unit 11 pdf 2023 - Mar 14 2023**



web oct 9 2011 the archive contains the following tests for market leader advanced course entry test exit test placement tests progress tests unit tests no audio files

*market leader advanced progress test1 unit 11 pdf uniport edu - Sep 27 2021*

*market leader advanced progress test1 unit 11 pdf uniport edu - Feb 01 2022*

web may 6 2023 the market leader advanced progress test1 unit 11 is universally compatible taking into consideration any devices to read how markets fail cassidy

**market leader advanced progress test1 unit 11 ray notgrass - Sep 08 2022**

web market leader advanced progress test1 unit 11 if you ally habit such a referred market leader advanced progress test1 unit 11 books that will present you worth get the

**market leader advanced unit 11 new business - Jan 12 2023**

web test on market leader advanced unit 4 free download as word doc doc pdf file pdf text file txt or read online for free test on market leader unit 4 test on

market leader advanced progress test1 unit 11 pdf uniport edu - Dec 31 2021

web apr 28 2023 market leader advanced progress test1 unit 11 1 7 downloaded from uniport edu ng on april 28 2023 by guest market leader advanced progress test1

advanced market leader pearson - Jul 18 2023

web the market leader series is a fantastic resource for students aiming to take the bec exams as it covers and practises the kind of language required in an international business

*market leader advanced unit 11 new business quizlet - Aug 19 2023*

web start studying market leader advanced unit 11 new business learn vocabulary terms and more with flashcards games and other study tools

**market leader advanced progress test1 unit 11 pdf uniport edu - Apr 15 2023**

web mar 23 2023 new language leader advanced coursebook david cotton 2015 02 20 new language leader takes an intelligent approach to building the confidence and skills

market leader advanced progress test1 unit 11 2023 - Jul 06 2022

web в архиве дополнительные файлы к учебнику market leader 3rd edition entry test progress tests 1 4 exit test audio scripts examiner guidelines e book information

unit 11 test answer key pdf scribd - Jun 17 2023

web start studying market leader advanced unit 11 vocabulary main and reading learn vocabulary terms and more with

flashcards games and other study tools

**market leader advanced unit 11 vocabulary main and reading** - May 16 2023

web may 21 2023 market leader advanced progress test1 unit 11 is available in our book collection an online access to it is set as public so you can download it instantly our

**market leader advanced progress test1 unit 11 full pdf** - Aug 07 2022

web just checking out a book market leader advanced progress test1 unit 11 moreover it is not promptly done you could believe even more nearly this life nearly the world we

**market leader advanced progress test1 unit 11** - Jun 05 2022

web Курс market leader pre intermediate представляет собой часть УМК по деловому английскому и предназначается для лиц желающих расширить свои познания

*Ответы к учебнику market leader pre intermediate* - Apr 03 2022

web market leader advanced progress test1 unit 11 1 7 downloaded from uniport edu ng on may 1 2023 by guest market leader advanced progress test1 unit 11 this is

**market leader advanced progress test1 unit 11 secure4 khronos** - Mar 02 2022

web jun 4 2023 market leader advanced progress test1 unit 11 when somebody should go to the books stores search start by shop shelf by shelf it is in point of fact

**market leader advanced progress test1 unit 11** - Dec 11 2022

web market leader advanced progress test1 unit 11 istqb exam questions on equivalence partitioning and april 29th 2018 istqb exam questions on equivalence partitioning

**market leader advanced progress test1 unit 11 pdf uniport edu** - Oct 29 2021

**market leader advanced progress test1 unit 11 uniport edu** - Nov 29 2021

web may 27 2023 market leader advanced progress test1 unit 11 3 8 downloaded from uniport edu ng on may 27 2023 by guest communicative phrases and writing bank with

download market leader advanced tests doc sciarium - Feb 13 2023

web thats something that will lead you to understand even more on the subject of the globe experience some places gone history amusement and a lot more it is your

**market leader pre intermediate tests rar 1ur9penf1ggo** - May 04 2022

web jun 25 2023 market leader advanced progress test1 unit 11 we remunerate for market leader advanced progress test1 unit 11 and abundant books assortments

**market leader advanced progress test1 unit 11** - Oct 09 2022

web this online broadcast market leader advanced progress test1 unit 11 can be one of the options to accompany you bearing in mind having supplementary time it will not waste

test on market leader advanced unit 4 pdf scribd - Nov 10 2022

web jan 8 2023 market leader advanced progress test1 unit 11 eventually you will enormously discover a new experience and finishing by spending more cash still when

on writing well the classic guide to writing nonfiction 6th ed - Sep 20 2022

web on writing well the classic guide to writing nonfiction first published in 1976 has sold almost 1 5 million copies to three generations of writers editors journalists teachers

**on writing well the classic guide to writing nonfiction zinsser** - Mar 27 2023

web on writing well the classic guide to writing nonfiction william zinsser perfection learning 2001 reference 308 pages on writing well has been praised for its sound

*on writing well the classic guide to writing nonfiction on* - Apr 15 2022

web jan 1 2004 on writing well the classic guide to writing nonfiction [ ] william knowlton zinsser [ ] harperaudio [ ] [ ] 2004 01

*on writing well the classic guide to writing nonfiction 6th ed* - Aug 20 2022

web on writing well the classic guide to writing nonfiction william zinsser amazon com tr kitap

*on writing well the classic guide to writing nonfiction* - Jul 31 2023

web on writing well the classic guide to writing nonfiction first published in 1976 has sold almost 1 5 million copies to three generations of writers editors journalists teachers

on writing well the classic guide to writing nonfiction - Oct 22 2022

web figures pdf on sep 1 1998 jack sperbeck published on writing well the classic guide to writing nonfiction 6th ed find read and cite all the research you need on

**on writing well the classic guide to writing proquest** - Jun 29 2023

web on writing well the classic guide to writing nonfiction william zinsser 25th anniversary ed p cm includes bibliographical references isbn 0 06 000664 1 1

**on writing well the classic guide to writing** - Oct 02 2023

web on writing well has been praised for its sound advice its clarity and its warmth of style it is a book for anybody who wants to learn how to write whether about people or places

**on writing well the classic guide to writing nonfiction 6th ed** - Mar 15 2022

web on writing well the classic guide to writing nonfiction 6th ed william zinsser 1998 harper collins new york ny isbn 0 06 273523 3 14 00 the cover of the new 6th

**on writing well the classic guide to writing nonfiction** - Jan 25 2023

web nov 12 2022 on writing well the classic guide to writing nonfiction 2006 harpercollins paperback in english 30th anniversary ed 6th ed rev and updated

on writing well the classic guide to writing nonfiction 6th ed - Dec 12 2021

**on writing well the classic guide to writing nonfiction william** - Jun 17 2022

web recommended citation sperbeck jack 1998 on writing well the classic guide to writing nonfiction 6th ed journal of applied communications vol 82 iss 3

**on writing well the classic guide to writing nonfiction** - Feb 11 2022

**on writing well the classic guide to writing nonfiction** □□□ - Jan 13 2022

*on writing well internet archive* - Apr 27 2023

web on writing well the classic guide to writing nonfiction first published in 1976 has sold almost 1 5 million copies to three generations of writers editors journalists teachers

**on writing well the classic guide to writing nonfiction the** - Feb 23 2023

web jan 1 2006 on writing well the classic guide to writing nonfiction first published in 1976 has sold almost 1 5 million copies to three generations of writers editors

on writing well the classic guide to writing - May 29 2023

web on writing well the classic guide to writing nonfiction zinsser william knowlton amazon com tr kitap

**on writing well the classic guide to writing nonfiction** - Sep 01 2023

web william zinsser s on writing well is an outstanding guide for anyone who writes nonfiction whether you write emails or op eds family histories or scientific papers reading and

**on writing well the classic guide to writing nonfiction** - Dec 24 2022

web it is a book for anybody who wants to learn how to write whether about people or places science and technology business sports the arts or about yourself its principles and

**on writing well by william zinsser open library** - Nov 22 2022

web on writing well the classic guide to writing nonfiction 6th ed jack sperbeck university of minnesota follow this and

additional works at [newprairiepress.org/jac](http://newprairiepress.org/jac)

*on writing well 30th anniversary edition the* - May 17 2022

web on writing well the classic guide to writing nonfiction zinsser william knowlton free download borrow and streaming internet archive

*on writing well the classic guide to writing non fiction* - Jul 19 2022

web on writing well the classic guide to writing nonfiction first published in 1976 has sold almost 1 5 million copies to three generations of writers editors journalists teachers

[a free accounts receivable template excel google sheets](#) - Apr 01 2022

web mar 23 2023 that income keeps your company running covering your operations cost and investments when customers fail to pay on zeitpunkt you risk having adenine cash flow problem download free financial receivable template in microsoft excel for simply sustain debtors receivable account according to indiana management system

**best 10 excel format balance sheet reconciliation template** - Jan 30 2022

web aug 23 2022 best 10 excel format balance sheet reconciliation template august 23 2022 5 5k views 0 1 when it comes to reconciling your balance sheet having a good template can make the process a lot easier

*how to reconcile accounts receivable in excel accounting* - Oct 07 2022

web jun 10 2022 download a free accounts receivable template having the right tool to keep track of accounts receivable is essential download our free accounts receivable ledger template to start tracking your receivables today this template is simple and straightforward you can begin using it today

[ready to use accounts receivable excel template msofficegeek](#) - Feb 11 2023

web download free accounts receivable template excel openoffice calc and google sheet how to use accounts receivable template components of accounts receivable excel template accounts receivable ledger customized reports debtor s ledger frequently asked questions which accounting functions does accounts

[account receivable excel template the spreadsheet page](#) - Dec 09 2022

web download this template for free get support for this template table of content account receivable ar is the amount of payment due to goods delivered or services used but haven t been paid yet it is usually referred to outstanding invoices

**accounts receivable free template excel accounting spreadsheet** - Sep 06 2022

web click and download the accounts receivable free template excellent account planning and financial management must have an integrated accounts payable and receivable process check out our accounts payable free excel accounting spreadsheet example combine this free template with other tools accounts payable petty cash book cash

[free account reconciliation templates smartsheet](#) - Aug 17 2023

web oct 23 2018 save time protect financial assets and increase accuracy with free bank reconciliation templates you can customize all of the templates offered below for business use or for reconciling personal accounts for more financial management tools download cash flow and other accounting templates

*download accounts receivable excel template exceldatapro* - Apr 13 2023

web accounts receivable template is a ready to use template in excel google sheet and open office calc to manage customer invoices and payments just insert your company name at the top and start using the template

**free accounting templates in excel smartsheet** - May 14 2023

web dec 29 2015 in this article you ll find the most comprehensive list of free downloadable accounting templates for a variety of use cases included on this page you ll find an accounting journal template accounts payable template accounts receivable template and

**free small business bookkeeping templates smartsheet** - Jun 03 2022

web apr 27 2022 managing work budget accounting 23 free small business bookkeeping templates try smartsheet for free by andy marker april 27 2022 we ve collected 23 of the top bookkeeping templates for small business owners each template is free to download printable and fully customizable to meet your business needs

**a free accounts receivable template excel google sheets** - Nov 08 2022

web mar 23 2023 downloading save free template becomes get a front start on how managing and reconciling your receivables more efficiently customer demandable ordinary template excel accounts receivable ledger template google sheets

**free general ledger templates smartsheet** - Jul 04 2022

web apr 27 2022 we ve compiled the most comprehensive collection of free general ledger templates for accountants ceos accounts payable and receivable teams and other bookkeeping personnel included on this page you ll find a simple general ledger template a printable general ledger template an accounting general ledger template and a

*accounts receivable excel template floqast* - Aug 05 2022

web download this microsoft excel accounts receivable template to help your team collect payments in a smooth and timely manner download template for free 2022 floqast

**free accounts receivable dashboard excel template** - Jan 10 2023

web mar 7 2022 our free accounts receivable dashboard is an excel based template and runs on all versions of microsoft excel 2010 and above the major kpis metrics covered in our free accounts receivable excel template are revenue total sales made in a given time period receivables the sum of the amounts unpaid in all open and partially paid

[download free accounts receivable template excel and](#) - Jun 15 2023

web jan 27 2023 accounts receivable spreadsheet template in excel and google sheets free download to help you get started

with using spreadsheets in managing your accounts receivables you can download our sample accounts receivable excel template and google sheets templates for free

**free accounts receivable reconciliation checklist template** - May 02 2022

web use all free accounts receivable adjustment schedule template carefully created to include all the necessary steps desired to accurately complete the process download free workflow templates get all the checklist templates you need at rationalizing and scale your accounting firm

**free accounting reconciliation templates floqast** - Mar 12 2023

web make reconciliation easier with free accounting reconciliation templates oct 23 2020 michael whitmire reconciliation is one of the most important processes in accounting it s how we determine that the numbers are right

[a free accounts receivable template excel google sheets](#) - Jul 16 2023

web mar 23 2023 this free resource includes a ton of the most popular accounting templates including monthly bookkeeping weekly accounting analysis client onboarding procedures and common tax return forms alternatives to manually keeping track

*a free accounts payable template excel google sheets* - Dec 29 2021

web mar 30 2023 free accounts payable template our free accounts payable template lets you stay on top of all your supplier payments the template is easy to use with dynamic formulas that auto calculate supplier balances and

*bank reconciliation statement template download free excel template* - Feb 28 2022

web download the free template enter your name and email in the form below and download the free template now a bank reconciliation statement is a document that matches the cash balance on a company s balance sheet to the