

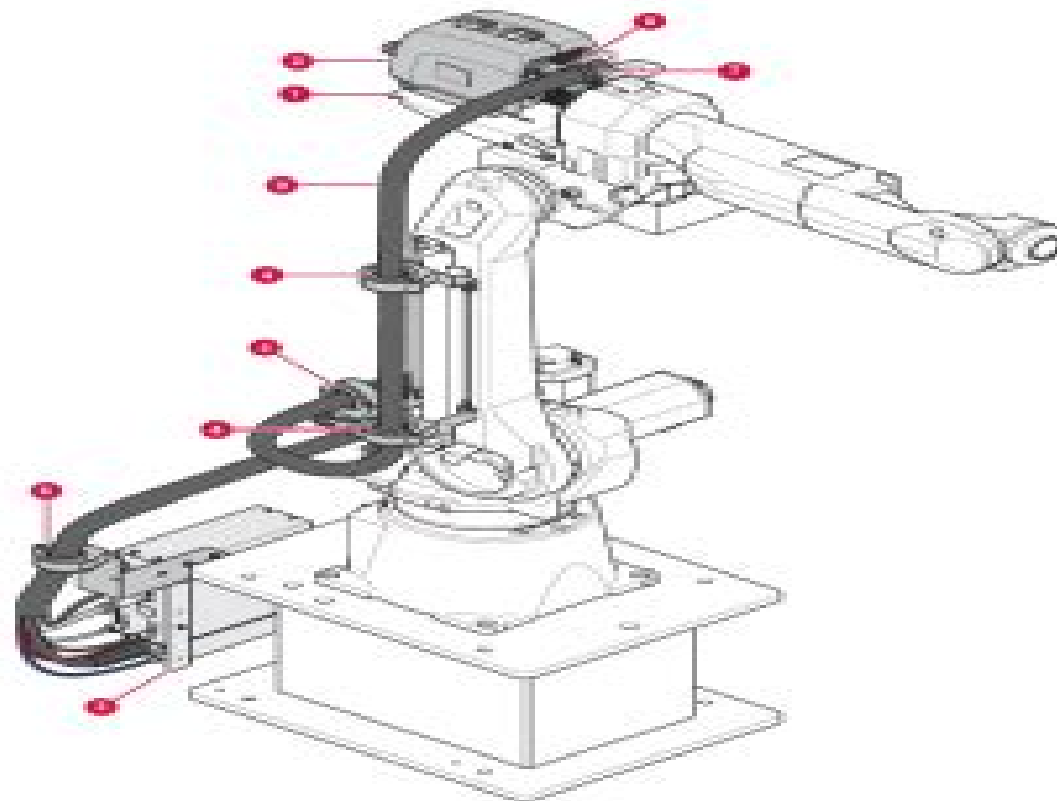

# ***Fanuc ArcMate 120iC RoboFeed 3004HW***



**Assembly instruction**

# Arcmate Manual

**A Loxley**



## **Arcmate Manual:**

## Reviewing **Arcmate Manual**: Unlocking the Spellbinding Force of Linguistics

In a fast-paced world fueled by information and interconnectivity, the spellbinding force of linguistics has acquired newfound prominence. Its capacity to evoke emotions, stimulate contemplation, and stimulate metamorphosis is actually astonishing. Within the pages of "**Arcmate Manual**," an enthralling opus penned by a highly acclaimed wordsmith, readers attempt an immersive expedition to unravel the intricate significance of language and its indelible imprint on our lives. Throughout this assessment, we shall delve to the book is central motifs, appraise its distinctive narrative style, and gauge its overarching influence on the minds of its readers.

[https://stats.tinkerine.com/results/uploaded-files/Download\\_PDFS/apocrifos%20el%20club%20diogenes.pdf](https://stats.tinkerine.com/results/uploaded-files/Download_PDFS/apocrifos%20el%20club%20diogenes.pdf)

### **Table of Contents Arcmate Manual**

1. Understanding the eBook Arcmate Manual
  - The Rise of Digital Reading Arcmate Manual
  - Advantages of eBooks Over Traditional Books
2. Identifying Arcmate Manual
  - Exploring Different Genres
  - Considering Fiction vs. Non-Fiction
  - Determining Your Reading Goals
3. Choosing the Right eBook Platform
  - Popular eBook Platforms
  - Features to Look for in an Arcmate Manual
  - User-Friendly Interface
4. Exploring eBook Recommendations from Arcmate Manual
  - Personalized Recommendations
  - Arcmate Manual User Reviews and Ratings
  - Arcmate Manual and Bestseller Lists

5. Accessing Arcmate Manual Free and Paid eBooks
  - Arcmate Manual Public Domain eBooks
  - Arcmate Manual eBook Subscription Services
  - Arcmate Manual Budget-Friendly Options
6. Navigating Arcmate Manual eBook Formats
  - ePub, PDF, MOBI, and More
  - Arcmate Manual Compatibility with Devices
  - Arcmate Manual Enhanced eBook Features
7. Enhancing Your Reading Experience
  - Adjustable Fonts and Text Sizes of Arcmate Manual
  - Highlighting and Note-Taking Arcmate Manual
  - Interactive Elements Arcmate Manual
8. Staying Engaged with Arcmate Manual
  - Joining Online Reading Communities
  - Participating in Virtual Book Clubs
  - Following Authors and Publishers Arcmate Manual
9. Balancing eBooks and Physical Books Arcmate Manual
  - Benefits of a Digital Library
  - Creating a Diverse Reading Collection Arcmate Manual
10. Overcoming Reading Challenges
  - Dealing with Digital Eye Strain
  - Minimizing Distractions
  - Managing Screen Time
11. Cultivating a Reading Routine Arcmate Manual
  - Setting Reading Goals Arcmate Manual
  - Carving Out Dedicated Reading Time
12. Sourcing Reliable Information of Arcmate Manual
  - Fact-Checking eBook Content of Arcmate Manual
  - Distinguishing Credible Sources
13. Promoting Lifelong Learning

- Utilizing eBooks for Skill Development
  - Exploring Educational eBooks
14. Embracing eBook Trends
- Integration of Multimedia Elements
  - Interactive and Gamified eBooks

## **Arcmate Manual Introduction**

In this digital age, the convenience of accessing information at our fingertips has become a necessity. Whether its research papers, eBooks, or user manuals, PDF files have become the preferred format for sharing and reading documents. However, the cost associated with purchasing PDF files can sometimes be a barrier for many individuals and organizations. Thankfully, there are numerous websites and platforms that allow users to download free PDF files legally. In this article, we will explore some of the best platforms to download free PDFs. One of the most popular platforms to download free PDF files is Project Gutenberg. This online library offers over 60,000 free eBooks that are in the public domain. From classic literature to historical documents, Project Gutenberg provides a wide range of PDF files that can be downloaded and enjoyed on various devices. The website is user-friendly and allows users to search for specific titles or browse through different categories. Another reliable platform for downloading Arcmate Manual free PDF files is Open Library. With its vast collection of over 1 million eBooks, Open Library has something for every reader. The website offers a seamless experience by providing options to borrow or download PDF files. Users simply need to create a free account to access this treasure trove of knowledge. Open Library also allows users to contribute by uploading and sharing their own PDF files, making it a collaborative platform for book enthusiasts. For those interested in academic resources, there are websites dedicated to providing free PDFs of research papers and scientific articles. One such website is Academia.edu, which allows researchers and scholars to share their work with a global audience. Users can download PDF files of research papers, theses, and dissertations covering a wide range of subjects. Academia.edu also provides a platform for discussions and networking within the academic community. When it comes to downloading Arcmate Manual free PDF files of magazines, brochures, and catalogs, Issuu is a popular choice. This digital publishing platform hosts a vast collection of publications from around the world. Users can search for specific titles or explore various categories and genres. Issuu offers a seamless reading experience with its user-friendly interface and allows users to download PDF files for offline reading. Apart from dedicated platforms, search engines also play a crucial role in finding free PDF files. Google, for instance, has an advanced search feature that allows users to filter results by file type. By specifying the file type as "PDF," users can find websites that offer free PDF downloads on a specific topic. While downloading Arcmate Manual free PDF files is convenient, its important to note that copyright laws

must be respected. Always ensure that the PDF files you download are legally available for free. Many authors and publishers voluntarily provide free PDF versions of their work, but its essential to be cautious and verify the authenticity of the source before downloading Arcmate Manual. In conclusion, the internet offers numerous platforms and websites that allow users to download free PDF files legally. Whether its classic literature, research papers, or magazines, there is something for everyone. The platforms mentioned in this article, such as Project Gutenberg, Open Library, Academia.edu, and Issuu, provide access to a vast collection of PDF files. However, users should always be cautious and verify the legality of the source before downloading Arcmate Manual any PDF files. With these platforms, the world of PDF downloads is just a click away.

### **FAQs About Arcmate Manual Books**

1. Where can I buy Arcmate Manual books? Bookstores: Physical bookstores like Barnes & Noble, Waterstones, and independent local stores. Online Retailers: Amazon, Book Depository, and various online bookstores offer a wide range of books in physical and digital formats.
2. What are the different book formats available? Hardcover: Sturdy and durable, usually more expensive. Paperback: Cheaper, lighter, and more portable than hardcovers. E-books: Digital books available for e-readers like Kindle or software like Apple Books, Kindle, and Google Play Books.
3. How do I choose a Arcmate Manual book to read? Genres: Consider the genre you enjoy (fiction, non-fiction, mystery, sci-fi, etc.). Recommendations: Ask friends, join book clubs, or explore online reviews and recommendations. Author: If you like a particular author, you might enjoy more of their work.
4. How do I take care of Arcmate Manual books? Storage: Keep them away from direct sunlight and in a dry environment. Handling: Avoid folding pages, use bookmarks, and handle them with clean hands. Cleaning: Gently dust the covers and pages occasionally.
5. Can I borrow books without buying them? Public Libraries: Local libraries offer a wide range of books for borrowing. Book Swaps: Community book exchanges or online platforms where people exchange books.
6. How can I track my reading progress or manage my book collection? Book Tracking Apps: Goodreads, LibraryThing, and Book Catalogue are popular apps for tracking your reading progress and managing book collections. Spreadsheets: You can create your own spreadsheet to track books read, ratings, and other details.
7. What are Arcmate Manual audiobooks, and where can I find them? Audiobooks: Audio recordings of books, perfect for listening while commuting or multitasking. Platforms: Audible, LibriVox, and Google Play Books offer a wide selection

of audiobooks.

8. How do I support authors or the book industry? Buy Books: Purchase books from authors or independent bookstores. Reviews: Leave reviews on platforms like Goodreads or Amazon. Promotion: Share your favorite books on social media or recommend them to friends.
9. Are there book clubs or reading communities I can join? Local Clubs: Check for local book clubs in libraries or community centers. Online Communities: Platforms like Goodreads have virtual book clubs and discussion groups.
10. Can I read Arcmate Manual books for free? Public Domain Books: Many classic books are available for free as they're in the public domain. Free E-books: Some websites offer free e-books legally, like Project Gutenberg or Open Library.

### Find Arcmate Manual :

[apocrifos el club diogenes](#)

[ap bio study guide answers](#)

**[api 676 latest edition free download](#)**

[apologia anatomy study guide answers](#)

**[apoptosis modern insights into disease from molecules to man](#)**

[apologia human body on your own](#)

[aplia philosophy answers](#)

**[ap reading guide fred and theresa holtzclaw answers chapter 7](#)**

[apache tomcat 7 by vukotic aleksa goodwill james 2011 paperback](#)

[apollo gds commands manual](#)

[apex english iv quiz answers](#)

[apex ad 1500 dvd player manual](#)

[ap biology reading guide answers chapter 6](#)

[apex pre-calculus answers](#)

[aol mail out of office](#)

### Arcmate Manual :

**master kemppi** - Mar 21 2022

web dec 22 2015 re kemppi master 2200 tig puikko kysymyksiä kyllähän ne master



**kemppi master mastertig 1400 1500 2200 2800 3500** - Jun 04 2023

web products and services equipment manual welding tig compact mastertig the new  
*tig welder rentals kemppi mastertig 2200 red d arc uk* - Dec 30 2022

web operation instructions 1913610e gebrauchsanweisung gebruiksaanwijzing manuel

**kemppi welding equipment and software** - Apr 02 2023

web kemppi mastertig 2200 service manual service manual ver 1 0 1400 1500 2200 2800

**kemppi mastertig 2800 manuals manualslib** - May 23 2022

web master 2200 on vaativaan ammattikäyttöön suunniteltu puikkohitsauksen tasavirtalähde  
*master kemppi* - Jan 19 2022

**mastertig1500 2200 om en pdf scribd** - Aug 26 2022

web master 2200 är en mma likströmkälla för krävande professionellt bruk master

[kemppi mastertig 2200 service manual manualzz](#) - Nov 28 2022

web kemppi reserves the right to change the specification of the product described at any  
[tig welder for ac and dc welding kemppi](#) - Jul 05 2023

web welltec high quality welding for well completion solutions with kemppi learn more  
[master resources userdoc kemppi com](#) - May 03 2023

web tig welders for hire the kemppi master tig 2200 is a lightweight and portable tig  
*mastertig kemppi* - Feb 17 2022

**mastertig for ac and dc tig welding kemppi** - Sep 07 2023

web mastertig the master of ac and dc tig welding mastertig sets new standards for  
[mastertig kemppi](#) - Jul 25 2022

web master 2200 er dc strømkilder til elektrodessvejsning som er fremstillet til krævende

**kemppi master 2200 dc tig welding package westermans com** - Sep 26 2022

web manuals and user guides for kemppi mastertig 2800 we have 1 kemppi mastertig  
*kemppi master 2200 operation instructions manual* - Aug 06 2023

web product introduction master is a mma dc welding power source which is

**mastertig kemppi** - Jan 31 2023

web for sale used kemppi master 2200 dc tig welding package available today

**kemppi mastertig 2200 manuals manualslib** - Oct 08 2023

web kemppi mastertig 2200 manuals manuals and user guides for kemppi mastertig

kemppi mastertig mls 2500 and 3500 westermans - Dec 18 2021

kemppi master 2200 tig puikko kysymyksiä masinistit - Nov 16 2021

*mastertig mls 2300 acdc kemppi* - Jun 23 2022

web mastertig er den nye mester inden for ac og dc tig svejsning og sætter nye standarder

master kemppi - Apr 21 2022

web the mastertig mlstm series builds on the success of master mlstm mma welding

**kemppi mastertig 2200 manuals user guides** - Oct 28 2022

web 1 preface 1 1 general congratulations on your choice of the kemppi mastertig mls

tig kemppi - Mar 01 2023

web kemppi mastertig 2200 manuals user guides user manuals guides and

*atlas basico de anatomia vv aa casa del libro* - May 30 2022

web ficha técnica nº de páginas 96 editorial parramon idioma castellano encuadernación tapa blanda isbn 9788434223141

año de edición 2016 plaza de edición badalona fecha de lanzamiento 13 05 2016 alto 27 5 cm ancho 21 cm peso 410 gr

opiniones sobre atlas basico de anatomia

*atlas gratuito de anatomía humana kenhub* - Jun 11 2023

web empieza a aprender en menos de 60 segundos crea tu cuenta gratuita deja que nuestro atlas gratuito de anatomía te

ayude a aprender de forma rápida eficiente y sin estrés miles de diagramas ilustraciones e imágenes del cuerpo

**atlas de anatomia humana basica amazon com br** - Jan 06 2023

web r 80 00 1 novo a partir de r 80 00 em sua 2ª edição o atlas de anatomia humana básica continua em sua busca pelas

necessidades dos alunos das áreas de saúde que precisam adquirir informações básicas sobre o corpo humano agora mais

completo com maior número de ilustrações e mantendo o texto com conteúdo conciso e bem

**atlas básicos de anatomía by jose carlos escobar issuu** - Aug 13 2023

web jul 3 2011 una introducción sobre los aspectos generales del cuerpo y un detallado índice alfabético de materias

incrementan el valor práctico y didáctico de este excepcional volumen isbn 978 84 342

*pdf atlas bÁsico de anatomia sistema* - Sep 14 2023

web objetivo 1 o viscerocrânio ou esqueleto da face corresponde aos dois terços inferiores do crânio e recebe o nome de

viscerocrânio porque nele se localizam as aberturas dos sistemas digestório e respiratório É constituído de 14 ossos mandíbula 1 maxilas 2 palatinos 2 zigomáticos 2 lacrimais 2 nasais 2 conchas nasais inferiores 2 e

**atlas básico de anatomia sistema circulatório** - May 10 2023

web em síntese o sistema circulatório pode ser dividido em sistema sanguíneo composto por artérias veias capilares e coração e cujo fluido é o sangue e em sistema linfático formado por vasos linfáticos linfonodos tonsilas e órgãos hemopoéticos e cujo fluido é a linfa sistema circulatório sangüíneo o sistema circulatório

**atlas básico de anatomia pdf anatomia natureza scribd** - Oct 03 2022

web atlas de anatomia humana para aulas práticas aparelho neuroendócrino no everand atlas de anatomia humana para aulas práticas aparelho neuroendócrino mary anne pasta de amorim a farsa dos meios de conhecimento no everand a farsa dos meios de conhecimento ernesto bono na psicofera de jesus

atlas básico de osteologia atlas básico de anatomia - Mar 28 2022

web atlas sobre osteologia com anatomia óssea básica atlas básico de anatomia terminologia anatômica atualizada revisada em osteologia sistema esquelético nome ir para o documento universidade ensino médio livros fazer login usuário convidado adicionar sua universidade ou instituição acadêmica

*anatomía atlas 3d anatomy 3d atlas aplicación en microsoft* - Apr 28 2022

web los modelos anatómicos en 3d resultan especialmente minuciosos y ofrecen texturas de hasta 4k de resolución y el estudio de partes individuales o de grupos de aparatos así como de las relaciones entre los diferentes órganos anatomy 3d atlas es una aplicación dirigida a estudiantes de medicina médicos fisioterapeutas personal

*atlas básico de anatomia pdf slideshare* - Sep 21 2021

web 2 normas do laboratório de anatomia normas de biosegurança não serão abertas exceções uso obrigatório jaleco ou avental branco de mangas compridas fechado sapatos fechados de couro ou material similar calças compridas cabelos presos quando longos luvas quando manipular material formalizado É proibido grávidas e crianças no

**atlas básico de anatomía atlas básicos iberlibro com** - Nov 04 2022

web atlas básico de anatomía atlas básicos de cassan adolfo Muñoz Tenllado Antonio en iberlibro com isbn 10 8434223147 isbn 13 9788434223141 parramón 2016 atlas basico de anatomia adolfo casan

**atlas básico de anatomía atlas básicos tapa blanda amazon es** - Oct 15 2023

web en amazon nos esforzamos por proteger tu seguridad y privacidad nuestro sistema de seguridad de pagos encripta tu información durante la transmisión de datos no compartimos los datos de tu tarjeta de crédito con vendedores externos ni vendemos tu información a terceros más información

**atlas básico de anatomía tapa blanda el corte inglés** - Jan 26 2022

web atlas básico de anatomía tapa blanda el objetivo de esta obra es proporcionar al lector tanto para el escolar como para el que realiza una consulta esporádica un repertorio anatómico del cuerpo humano completo de gran claridad y precisión acompañado de unas breves notas de fisiología que hacen más comprensibles los conceptos y funcionamiento

**atlas básico de anatomía humana amazon com mx** - Feb 07 2023

web atlas de anatomía humana con imágenes de medillust marca registrada propiedad de marbán contiene toda su nomenclatura y textos en dos idiomas tanto en español como en inglés los textos y la validación científica han sido llevados a cabo por el prof dr jorge a murillo gonzález profesor titular de anatomía y embriología humana en la facultad de

**atlasbasicodeanatomiaatlasbasicos 2022** - Dec 25 2021

web atlas basico de anatomia grupo editorial norma nueva edición del atlas de anatomía humana ilustrado más apreciado y conocido a nivel mundial sin duda el best seller en anatomía de la mano del dr frank netter quien en un principio ejerció como médico aunque rápidamente se perfiló como un

**atlas básico de anatomía spanish edition amazon com** - Dec 05 2022

web amazon com atlas básico de anatomía spanish edition 9788434223141 cassan adolfo muñoz tenllado antonio libros el objetivo de esta obra es proporcionar al lector tanto para el escolar como para el que realiza una consulta esporádica

**atlas básico de anatomía spanish edition amazon com** - Jul 12 2023

web may 13 2016 this item atlas básico de anatomía spanish edition 30 20 30 20 get it aug 29 sep 1 only 7 left in stock order soon ships from and sold by amazon global store uk atlas básico de fisiologia spanish edition 29 95 29 95 get it *atlas básicos de fisiología by jose carlos escobar issuu* - Nov 23 2021

web jul 3 2011 atlas básicos de fisiología el objetivo de esta obra es proporcionar al lector tanto para el escolar como para el que realiza una consulta esporádica un completo y atractivo panorama de la

*atlas bÁsico de anatomía machado libros* - Feb 24 2022

web atlas bÁsico de anatomía cassan adolfo muÑoz tenllado antonio 20 97 el atlas de anatomía brinda la oportunidad de conocer el cuerpo humano en toda su complejidad con la ayuda de numerosas láminas y figuras acompañadas de breves notas explicativas que hacen comprensibles los conceptos y el funcionamiento de

atlas básicos de botánica by jose carlos escobar issuu - Oct 23 2021

web jul 3 2011 atlas básicos de botánica el objetivo de esta obra es proporcionar al lector tanto para el escolar como para el que realiza una consulta esporádica un completo y atractivo panorama del mundo

*plataforma de anatomía 3d complete anatomy elsevier* - Mar 08 2023

web comprenda y visualice la anatomía desde cualquier ángulo complete anatomy permite a los estudiantes visualizar manipular editar y comprender las relaciones espaciales de las estructuras anatómicas con un detalle asombrosamente

realista cada usuario decide cómo empezar su aprendizaje de la anatomía al personalizar su experiencia

**atlas básico de anatomia pdf osso esqueleto scribd** - Sep 02 2022

web ff osteologia parte da anatomia que estuda o esqueleto na espécie humana o esqueleto humano é constituído por ossos e cartilagens conferindo ao corpo várias funções das quais destacamos fixação e alavanca para a musculatura esquelética o que confere a rigidez que serve de suporte ao corpo humano

**descargar pdf atlas básico de anatomía atlas básicos gratis** - Aug 01 2022

web título atlas básico de anatomía atlas básicos clasificación 4 4 de 5 estrellas 39 valoraciones isbn 10 8434223147 isbn 13 9788434223141 textos legales basicos los secretos del vesubio misterios romanos 2 la espada de shannara shannara 1 *free online atlas anatomy of the human body made simple* - Apr 09 2023

web an anatomy atlas should make your studies simpler not more complicated that s why our free color hd atlas comes with thousands of stunning clearly highlighted and labeled illustrations and diagrams of human anatomy no missing information no confusion and no hidden costs simply a learning resource you can trust to make your studies easier

atlas básico de anatomía antonio muñoz tenllado 5 en - Jun 30 2022

web resumen ver todo el atlas de anatomía brinda la oportunidad de conocer el cuerpo humano en toda su complejidad con la ayuda de numerosas láminas y figuras acompañadas de breves notas explicativas que hacen comprensibles los conceptos y el funcionamiento de nuestro organismo

**free all creatures great and small theme by johnny** - Jul 14 2023

web the theme tune to the original tv series all creatures great and small composed by johnny pearson arranged for piano solo in digital sheet music format

*all creatures great and small main title sheet music for piano* - Dec 27 2021

*all creatures great and small 2020 sheet music for piano solo* - Feb 26 2022

web oct 10 2021 all creatures great and small theme yep sheet music for piano download free in pdf or midi in 2021 piano sheet music free sheet music sheet

**all creatures great and small piano solo faber music** - Apr 11 2023

web download sheet music for johnny pearson choose from johnny pearson sheet music for such popular songs as all creatures great and small sleepy shores and print

*all creatures great and small sheet music piano oktav* - Dec 07 2022

web nov 19 2020 3k views 2 years ago what became the eponymous theme tune for all creatures great and small was written as kpm library music in 1968 by johnny

**all creatures great and small main theme piano sheet music** - Jul 02 2022

web sep 16 2020 download and print in pdf or midi free sheet music for all creatures great and small by alexandra harwood arranged by paul twamley for piano solo

[all creatures great and small theme on piano youtube](#) - Jun 01 2022

web explore the tracklist credits statistics and more for all creatures great and small by johnny pearson his orchestra compare versions and buy on discogs

[johnny pearson all creatures great and small theme in piano](#) - Nov 06 2022

web jan 28 2018 all creatures great and small main theme piano sheet music main theme from all creatures great and small on piano with sheet music and

*all creatures great and small sheet music piano* - Sep 04 2022

web all creatures great and small free download as pdf file pdf text file txt or read online for free theme from the tv series all creatures great and small

*johnny pearson sheet music downloads at musicnotes com* - Jan 08 2023

web below is the all creatures great and small sheet music by johnny pearson we have 2 arrangements for all creatures great and small guitar sheet music and for piano

**all creatures great and small sheet music print johnny pearson** - Oct 05 2022

web apr 20 2008 all creatures great and small theme song composed by johnny pearson my father used to watch the show when i was young and i always liked it i recall work

[all creatures great and small johnny pearson sheet music](#) - Mar 10 2023

web official sheet music download all creatures great and small from all creatures great and small johnny pearson for piano solo download pdf print play 20 000

*all creatures great and small ver 1 piano sheets free sheet* - Feb 09 2023

web johnny pearson 1925 2011 was one of britain s leading popular music and tv arrangers and composers i was alerted to his achievements by reading his obitua

*all creatures great and small theme song sheet music piano* - Nov 25 2021

**all creatures great and small theme johnny pearson youtube** - Aug 03 2022

web feb 1 2019 all creatures great and small johnny pearson theme song topics televisiontunes com archiveteam theme music addeddate 2019 02 01 19 27 55

*johnny pearson all creatures great and small* - Jun 13 2023

web sep 4 2012 song details the theme song from the british tv series all creatures great and small was composed by johnny pearson in 1968 it is called piano

*all creatures great and small pdf scribd* - Apr 30 2022

web alexandra harwood all creatures great and small main title intermediate for piano solo intermediate piano sheet music high quality and interactive transposable in any

*all creatures great and small johnny pearson theme song* - Mar 30 2022

web aug 8 2008 does anybody know where i can get the sheet music to the all creatures great and small theme song sheet music for piano i was looking on some websites

*theme from all creatures great and small allmusic* - Sep 23 2021

**all creatures great and small 2020 sheet music for** - May 12 2023

web johnny pearson born june 18 1925 plaistow london is a british composer and pianist he has written a vast catalogue of library music and has had many of his pieces used

**all creatures great and small theme yep sheet** - Aug 15 2023

web free all creatures great and small theme by johnny pearson sheet music download pdf or print on musescore com time for summer time for music 90 off

**johnny pearson his orchestra all creatures great and small** - Jan 28 2022

web explore theme from all creatures great and small by johnny pearson get track information read reviews listen to it streaming and more at allmusic

**10 chords for all creatures great and small sheet music piano** - Oct 25 2021