

Workshop-Manual

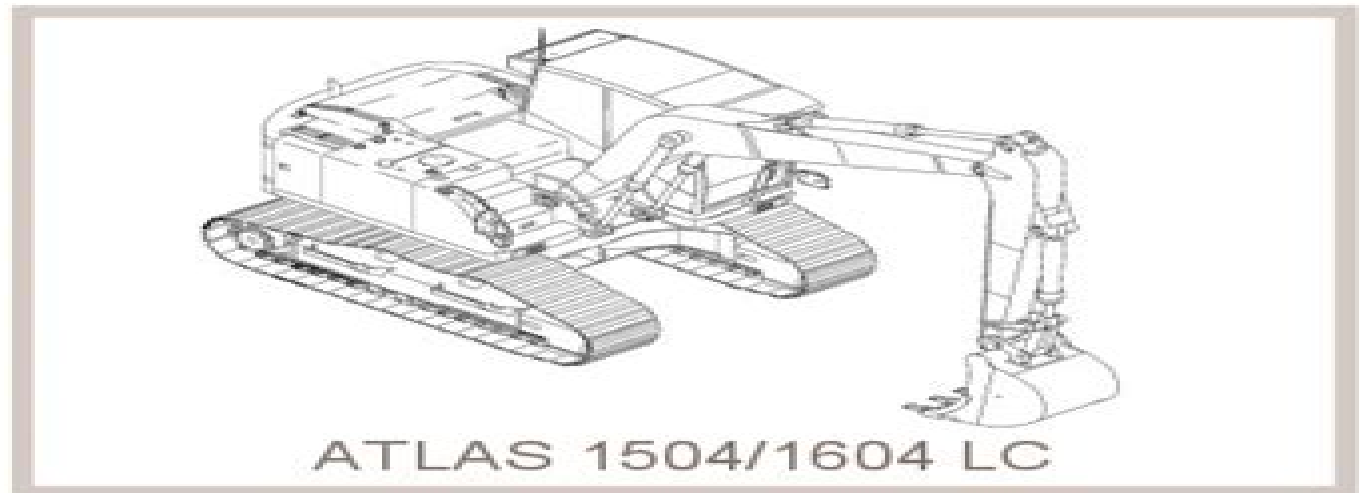

Atlas 1504 Service Manual

JA Banks



Atlas 1504 Service Manual:

Moody's Manual of Railroads and Corporation Securities ,1923 Field Manuals United States. War Department,1948
Universal Cyclopaedia and Atlas Charles Kendall Adams,Rossiter Johnson,1901 **The Student's Manual** Chandler
B. Beach,1909 **Universal Cyclopdia and Atlas** ,1903 *Moody's Manual of Industrial and Miscellaneous Securities*
,1922 **Trademark Trial and Appeal Board Manual of Procedure (TBMP)**. United States. Trademark Trial and
Appeal Board,2003 **Moody's Manual of Investments** John Sherman Porter,1929 American government securities 1928
53 in 5 annual vols v 1 Railroad securities 1952 53 Transportation v 2 Industrial securities v 3 Public utility securities v 4
Government securities 1928 54 v 5 Banks insurance companies investment trusts real estate finance and credit companies
1928 54 **Technical Papers of the U.S. Fish and Wildlife Service** ,1980 *Popular Mechanics* ,1945-11 Popular
Mechanics inspires instructs and influences readers to help them master the modern world Whether it s practical DIY home
improvement tips gadgets and digital technology information on the newest cars or the latest breakthroughs in science PM is
the ultimate guide to our high tech lifestyle

Getting the books **Atlas 1504 Service Manual** now is not type of challenging means. You could not on your own going when books collection or library or borrowing from your links to gate them. This is an no question easy means to specifically acquire lead by on-line. This online notice Atlas 1504 Service Manual can be one of the options to accompany you considering having further time.

It will not waste your time. acknowledge me, the e-book will unquestionably heavens you further matter to read. Just invest little grow old to retrieve this on-line message **Atlas 1504 Service Manual** as skillfully as review them wherever you are now.

https://stats.tinkerine.com/public/publication/Documents/audi_80_engine_manual.pdf

Table of Contents Atlas 1504 Service Manual

1. Understanding the eBook Atlas 1504 Service Manual
 - The Rise of Digital Reading Atlas 1504 Service Manual
 - Advantages of eBooks Over Traditional Books
2. Identifying Atlas 1504 Service Manual
 - Exploring Different Genres
 - Considering Fiction vs. Non-Fiction
 - Determining Your Reading Goals
3. Choosing the Right eBook Platform
 - Popular eBook Platforms
 - Features to Look for in an Atlas 1504 Service Manual
 - User-Friendly Interface
4. Exploring eBook Recommendations from Atlas 1504 Service Manual
 - Personalized Recommendations
 - Atlas 1504 Service Manual User Reviews and Ratings
 - Atlas 1504 Service Manual and Bestseller Lists

5. Accessing Atlas 1504 Service Manual Free and Paid eBooks
 - Atlas 1504 Service Manual Public Domain eBooks
 - Atlas 1504 Service Manual eBook Subscription Services
 - Atlas 1504 Service Manual Budget-Friendly Options
6. Navigating Atlas 1504 Service Manual eBook Formats
 - ePub, PDF, MOBI, and More
 - Atlas 1504 Service Manual Compatibility with Devices
 - Atlas 1504 Service Manual Enhanced eBook Features
7. Enhancing Your Reading Experience
 - Adjustable Fonts and Text Sizes of Atlas 1504 Service Manual
 - Highlighting and Note-Taking Atlas 1504 Service Manual
 - Interactive Elements Atlas 1504 Service Manual
8. Staying Engaged with Atlas 1504 Service Manual
 - Joining Online Reading Communities
 - Participating in Virtual Book Clubs
 - Following Authors and Publishers Atlas 1504 Service Manual
9. Balancing eBooks and Physical Books Atlas 1504 Service Manual
 - Benefits of a Digital Library
 - Creating a Diverse Reading Collection Atlas 1504 Service Manual
10. Overcoming Reading Challenges
 - Dealing with Digital Eye Strain
 - Minimizing Distractions
 - Managing Screen Time
11. Cultivating a Reading Routine Atlas 1504 Service Manual
 - Setting Reading Goals Atlas 1504 Service Manual
 - Carving Out Dedicated Reading Time
12. Sourcing Reliable Information of Atlas 1504 Service Manual
 - Fact-Checking eBook Content of Atlas 1504 Service Manual
 - Distinguishing Credible Sources
13. Promoting Lifelong Learning

- Utilizing eBooks for Skill Development
 - Exploring Educational eBooks
14. Embracing eBook Trends
- Integration of Multimedia Elements
 - Interactive and Gamified eBooks

Atlas 1504 Service Manual Introduction

In this digital age, the convenience of accessing information at our fingertips has become a necessity. Whether its research papers, eBooks, or user manuals, PDF files have become the preferred format for sharing and reading documents. However, the cost associated with purchasing PDF files can sometimes be a barrier for many individuals and organizations. Thankfully, there are numerous websites and platforms that allow users to download free PDF files legally. In this article, we will explore some of the best platforms to download free PDFs. One of the most popular platforms to download free PDF files is Project Gutenberg. This online library offers over 60,000 free eBooks that are in the public domain. From classic literature to historical documents, Project Gutenberg provides a wide range of PDF files that can be downloaded and enjoyed on various devices. The website is user-friendly and allows users to search for specific titles or browse through different categories. Another reliable platform for downloading Atlas 1504 Service Manual free PDF files is Open Library. With its vast collection of over 1 million eBooks, Open Library has something for every reader. The website offers a seamless experience by providing options to borrow or download PDF files. Users simply need to create a free account to access this treasure trove of knowledge. Open Library also allows users to contribute by uploading and sharing their own PDF files, making it a collaborative platform for book enthusiasts. For those interested in academic resources, there are websites dedicated to providing free PDFs of research papers and scientific articles. One such website is Academia.edu, which allows researchers and scholars to share their work with a global audience. Users can download PDF files of research papers, theses, and dissertations covering a wide range of subjects. Academia.edu also provides a platform for discussions and networking within the academic community. When it comes to downloading Atlas 1504 Service Manual free PDF files of magazines, brochures, and catalogs, Issuu is a popular choice. This digital publishing platform hosts a vast collection of publications from around the world. Users can search for specific titles or explore various categories and genres. Issuu offers a seamless reading experience with its user-friendly interface and allows users to download PDF files for offline reading. Apart from dedicated platforms, search engines also play a crucial role in finding free PDF files. Google, for instance, has an advanced search feature that allows users to filter results by file type. By specifying the file type as "PDF," users can find websites that offer free PDF downloads on a specific topic. While downloading Atlas 1504 Service Manual free PDF files is convenient, its

important to note that copyright laws must be respected. Always ensure that the PDF files you download are legally available for free. Many authors and publishers voluntarily provide free PDF versions of their work, but its essential to be cautious and verify the authenticity of the source before downloading Atlas 1504 Service Manual. In conclusion, the internet offers numerous platforms and websites that allow users to download free PDF files legally. Whether its classic literature, research papers, or magazines, there is something for everyone. The platforms mentioned in this article, such as Project Gutenberg, Open Library, Academia.edu, and Issuu, provide access to a vast collection of PDF files. However, users should always be cautious and verify the legality of the source before downloading Atlas 1504 Service Manual any PDF files. With these platforms, the world of PDF downloads is just a click away.

FAQs About Atlas 1504 Service Manual Books

1. Where can I buy Atlas 1504 Service Manual books? Bookstores: Physical bookstores like Barnes & Noble, Waterstones, and independent local stores. Online Retailers: Amazon, Book Depository, and various online bookstores offer a wide range of books in physical and digital formats.
2. What are the different book formats available? Hardcover: Sturdy and durable, usually more expensive. Paperback: Cheaper, lighter, and more portable than hardcovers. E-books: Digital books available for e-readers like Kindle or software like Apple Books, Kindle, and Google Play Books.
3. How do I choose a Atlas 1504 Service Manual book to read? Genres: Consider the genre you enjoy (fiction, non-fiction, mystery, sci-fi, etc.). Recommendations: Ask friends, join book clubs, or explore online reviews and recommendations. Author: If you like a particular author, you might enjoy more of their work.
4. How do I take care of Atlas 1504 Service Manual books? Storage: Keep them away from direct sunlight and in a dry environment. Handling: Avoid folding pages, use bookmarks, and handle them with clean hands. Cleaning: Gently dust the covers and pages occasionally.
5. Can I borrow books without buying them? Public Libraries: Local libraries offer a wide range of books for borrowing. Book Swaps: Community book exchanges or online platforms where people exchange books.
6. How can I track my reading progress or manage my book collection? Book Tracking Apps: Goodreads, LibraryThing, and Book Catalogue are popular apps for tracking your reading progress and managing book collections. Spreadsheets: You can create your own spreadsheet to track books read, ratings, and other details.
7. What are Atlas 1504 Service Manual audiobooks, and where can I find them? Audiobooks: Audio recordings of books,

perfect for listening while commuting or multitasking. Platforms: Audible, LibriVox, and Google Play Books offer a wide selection of audiobooks.

8. How do I support authors or the book industry? Buy Books: Purchase books from authors or independent bookstores. Reviews: Leave reviews on platforms like Goodreads or Amazon. Promotion: Share your favorite books on social media or recommend them to friends.
9. Are there book clubs or reading communities I can join? Local Clubs: Check for local book clubs in libraries or community centers. Online Communities: Platforms like Goodreads have virtual book clubs and discussion groups.
10. Can I read Atlas 1504 Service Manual books for free? Public Domain Books: Many classic books are available for free as they're in the public domain. Free E-books: Some websites offer free e-books legally, like Project Gutenberg or Open Library.

Find Atlas 1504 Service Manual :

audi 80 engine manual

audi a3 mmi user manual

audi a6 2007 user manual

audi 100 workshop manual

audi b5 s4 bentley manual

attack that debt surefire strategies for defeating debt and stopping debt collectors

~~audi a3 service manual~~

~~audi a3 manual warning lights~~

atwood hydro flame furnace manual 8500

audi a3 repair manual free

audi a4 technical manual

~~audi b5 1999 workshop service manual repair~~

au del raison coeur lucy t1 ebook

~~audi abc workshop manual~~

audi a6 42 manual transmission

Atlas 1504 Service Manual :

secondary geography form 2 student s book text - Jul 13 2023

web these geography notes follows the kenya certificate of secondary education geography form 2 syllabus our notes have been prepared by qualified professional teachers

geography form 2 lesson plans newsblaze co ke - Dec 06 2022

web secondary geography form 3 sb this edition guides the learner in studies in physical geography the learner is also guided in studies in the practical aspects of geography

a comparison of secondary school curricula in terms of - Jul 01 2022

web field studies and seminars are carried out periodically in different places and on different subjects club advisor dr cihan bayrakdar e mail cihanbyr istanbul edu tr head

download form 2 geography notes teacher co ke - Jun 12 2023

web sep 14 2023 introducing geography form 2 stating the areas of focus in form 2 geography asking questions answering questions klb secondary geography

secondary geography form 3 sb klbbooks - Oct 04 2022

web dec 2 2022 geography form 2 notes december 2 2022 mj topic 1 internal land forming processes notes click to view topic 2

klb secondary geography form two copy uniport edu - Mar 29 2022

web geomorphometry automatic landform classification in the past landforms were represented in physiographic and morphometric maps by hand drawing with

form 2 archives klbbooks - Feb 08 2023

web aug 23 2023 introducing geography form 2 stating the areas of focus in form 2 geography asking questions answering questions klb secondary geography

klb secondary geography form two uniport edu - May 31 2022

web jun 18 2023 klb secondary geography form two 1 5 downloaded from uniport edu ng on june 18 2023 by guest klb secondary geography form two getting the books

geography notes form 2 free download kcse - Aug 14 2023

web geography notes form 2 geography notes kcse form 2 topics form 2 geography syllabus klb geography form 2 geography form 2 questions and answers

klb schemes of work for secondary schools in kenya pdf - Nov 24 2021

web free click collect sku 2010114000108 this product does not have any reviews yet secondary physics form 2 6th ed add to

basket secondary geography form 2

[klb secondary geography form 2 students book shopit](#) - Nov 05 2022

web 2023 class 8 success mathematics schemes of work term 2 ksh 70 00 2023 grade 6 cbc assessment report book ksh 150 00 ksh 100 00 2023 form 4 new horizon english

history and government form 2 text book centre - Sep 22 2021

ib diploma programme the british international school the bis - Feb 25 2022

web discover and share books you love on goodreads

secondary geography form 2 klb text books - Jan 07 2023

web home books and media books academic books secondary school books klb secondary geography form 2 students book klb secondary geography form 2

loading interface goodreads - Dec 26 2021

web sep 6 2023 introducing geography form 2 stating the areas of focus in form 2 geography asking questions answering questions klb secondary geography

geography form 2 lesson plans citizen news line - Oct 24 2021

2022 form 2 klb geograhly schemes of work term 2 - Sep 03 2022

web climate change education cce is an approach that has started to form its own identity in recent years as part of environmental education ee education for sustainable

[geography İstanbul](#) - Apr 29 2022

web ib diploma programme the british international school has been authorized to deliver the ib diploma programme since 1995 to be an ib school in İstanbul the ib diploma

[geography notes for form two all](#) - Mar 09 2023

web secondary geography form 2 klb text books secondary geography form 2 klb text books available secondary breakthrough geography form 2 ksh 493 00

geography form 2 lesson plans - May 11 2023

web 01 open the form 2 geography textbook to the first page 02 fill in your name date and other personal information in the designated spaces 03 turn to the table of contents and

geography form 2 notes knec study materials - Aug 02 2022

web klb secondary geography form two 1 1 downloaded from uniport edu ng on september 8 2023 by guest klb secondary

geography form two this is likewise one of the factors

get the free form 2 geography textbook pdf pdfiller - Apr 10 2023

web secondary biology form 2 pb ksh 627 00 add to cart secondary chemistry form 2 sb ksh 627 00 add to cart secondary

christian religious education students book 2 ksh

geomorphometry automatic landform classification İstanbul - Jan 27 2022

web find and download klb schemes of work for secondary schools in kenya in pdf format for al subjets klb geography

schemes of work klb geography form 1 schemes of

science 7 final exam review improved version original quizlet - Aug 31 2023

web scientific method steps click the card to flip 1 state the problem 2 gather information 3 form hypothesis 4 test hypothesis

experiment 5 analyze data 6 draw

7th grade science final exam review 68 plays quizizz - Oct 21 2022

web 7th grade science final exam review aaron helm 68 plays 30 questions copy edit introducing new paper mode no student

devices needed know more show answers

7 sınıf 21 deneme 2021 2022 1 güneş sistemi ve Ötesi - Jan 24 2023

web oct 1 2021 5 1 1 güneş in yapısı ve Özellikleri 5 1 2 ay in yapısı ve Özellikleri 5 1 3 ay in hareketleri ve evreleri 5 1 4

güneş dünya ve ay 2 Ünite canlıların dünyası

final exam review science 7 victorschools org - May 28 2023

web general review of science 7 vocab and concepts unit one practice for final science 7 8 chemistry review packet science 7

8 ecology 1 ecology 1 answer key final

science final exam 7th grade proprofs quiz - Feb 10 2022

web mar 22 2023 1 which is not made from cells a mushroom b sand c dog d leaf correct answer b sand explanation sand is

not made from cells because it is a

science 7 practice exam proprofs quiz - Apr 14 2022

web mar 22 2023 science 7 practice exam approved edited by proprofs editorial team written by computers5 questions 29

attempts 2 845 updated mar 22 2023

grade 7 natural sciences final exam 22 pages 18 - Dec 11 2021

web this final exam paper includes 22 pages first 11 pages only has questions and next 11 pages with answers students can

solve the questions and then check their answers

final exam review earth science 7 flashcards quizlet - Sep 19 2022

web browse 500 sets of final exam review earth science 7 flashcards options 82 terms science 7 planet earth vocabulary a

natural material composed of one or more

[science 7r final flashcards quizlet](#) - Mar 26 2023

web ffms science 7r final exam review learn with flashcards games and more for free

[test the science 7 final exam review pdf weathering](#) - Jul 30 2023

web download now of 8 6 18 2016 test the science 7 final exam review quizlet name 13 written questions 1 insulator a incorrect you said a material that does not

[up class 7th science khan academy](#) - Mar 14 2022

web up class 7th science 20 units 60 skills unit 1 man science and technology unit 2 fiber to fabric unit 3 structure of nature and matter unit 4 physical and chemical changes

[science 7 summative test pdf light heat transfer scribd](#) - Aug 19 2022

web instructions there are forty 40 questions in this paper and each is followed by four possible answers choose the one that best completes the statement or answers the

[science 7 final exam review flashcards quizlet](#) - Jun 28 2023

web science 7 final exam review get a hint science click the card to flip a system of knowledge about the natural world and methods used to find that knowledge click the

[cbse sample papers for class 7 science click to download](#) - Jan 12 2022

web as exams are around the corner students are all set to appear for their cbse class 7 final exams after finishing their revisions now it s time to practise some sample papers to

science final review grade 7 proprofs quiz - Nov 09 2021

web mar 22 2023 correct answer

7th grade final science exam flashcards quizlet - Jun 16 2022

web 1 722 flashcards learn test match created by adamhall35 final test will be multiple choice and true and false for the best practice go to test and pick true and false and

7 final exam science revised edition flashcards quizlet - Apr 26 2023

web 7 final exam science revised edition flashcards quizlet solute click the card to flip the substance being dissolved in a solution click the card to flip 1 172 flashcards

[grade 7 science final exam edquest](#) - Jul 18 2022

web grade 7 science final exam science in action textbook edition unit a interactions and ecosystems section 1 relationships an ecosystem thrives

grade 7 science final examination pdf solubility liquids - Feb 22 2023

web 8 9 22 2 19 pm science 7 final examination first grading period science 7 final examination first grading period don t watch the clock do what it does

science grade 7 final exam review flashcards quizlet - Dec 23 2022

web which sub branch is the study of stars and planets astronomy which sub branch is the study of plants botany which sub branch is the study if substances and how the change

science final exam flashcards quizlet - Nov 21 2022

web quizletprepare for your science final exam with this set of flashcards covering various topics such as chemistry physics biology and astronomy you can learn test and

7 sınıf fen bilimleri yazılı soruları 2023 2024 sorubak com - Oct 09 2021

web sınıf fen bilimleri yazılı soruları Çöz 2023 2024 7 sınıf fen bilimleri yazılı soruları ve cevapları ortaokullarda diğer derslerde olduğu gibi fen bilimleri dersinde de bir dönem

science 7 final exam review form fill out and sign printable - May 16 2022

web show details how it works open the grade 7 science test pdf p and follow the instructions easily sign the grade 7 science test questions and answers with your finger send filled

prescott harley and klein s microbiology google books - May 12 2023

web this edition of microbiology provides a balanced comprehensive introduction to all major areas of microbiology the text is appropriate for students preparing for careers in medicine

prescott harley and klein s microbiology worldcat org - Nov 06 2022

web prescott harley and klein s microbiology worldcat org prescott harley and klein s microbiology 8 reviews authors joanne m willey linda sherwood christopher j woolverton lansing m prescott summary providing a comprehensive introduction to major areas of microbiology this work is for microbiology majors and mixed majors

prescott harley and klein s microbiology worldcat org - Jan 28 2022

web prescott harley and klein s microbiology authors joanne m willey linda sherwood christopher j woolverton lansing m prescott summary providing a comprehensive introduction to major areas of microbiology this work is for microbiology majors and mixed majors courses

microbiologie lansing m prescott john p harley donald a klein - Jan 08 2023

web jul 30 1999 lansing m prescott john p harley donald a klein de boeck université jul 30 1999 microbiology 1014 pages ce traité unique en son genre couvre tous les aspects de la

microbiología lansing m prescott john p harley donald a klein - Dec 07 2022

web microbiología lansing m prescott john p harley donald a klein mcgraw hill interamericana 2004 microbiology 1240 pages

microbiology prescott lansing m harley john p klein donald - Jul 02 2022

web mar 2 2004 prescott harley and klein s 6th edition provides a balanced comprehensive introduction to all major areas of microbiology because of this balance microbiology 6 e is appropriate for students preparing for careers in medicine dentistry nursing and allied health as well as research teaching and industry

prescott harley and klein s microbiology google books - Aug 03 2022

web mcgraw hill higher education 2008 science 1088 pages available with prescott harley and klein s microbiology seventh edition are more than 150 animations to harness the visual impact of microbiology processes in motion

prescott harley and klein s microbiology worldcat org - Mar 10 2023

web prescott harley and klein s microbiology authors joanne m willey linda sherwood christopher j woolverton lansing m prescott summary this edition of microbiology provides a balanced comprehensive introduction to all major areas of microbiology

prescott harley klein s microbiology 7th edition nosnibor - Jul 14 2023

web prescott harley klein s microbiology 7th edition nosnibor ebook pdf pdf google drive sign in

prescott harley and klein s microbiology worldcat org - Apr 30 2022

web prescott harley and klein s microbiology authors joanne m willey linda sherwood christopher j woolverton lansing m prescott summary provides a balanced and comprehensive introduction to various areas of microbiology

microbiology by lansing m prescott open library - Oct 05 2022

web microbiology by lansing m prescott john p harley donald a klein 1993 w m c brown publishers edition in english 2nd ed

prescott harley and klein s microbiology 7th ed pdf - Feb 09 2023

web mar 20 2021 prescott harley and klein s microbiology 7th ed free pdf download joanne m willey 1 222 pages year 2008 microbiology

file download prescott harley and klein s microbiology - Feb 26 2022

web prescott harley and klein s microbiology 7th ed checking for file health download author joanne m willey linda sherwood christopher j woolverton language english release year 2008 file size 78 97mb number of page 1222 similar prescott harley and klein s microbiology 7th ed pdfdrive hope give books away get books you want

microbiologie de boeck supérieur - Jun 13 2023

web 5e édition juillet 2018 1120 pages 9782807308022 la microbiologie de prescott un ouvrage de référence décrit la microbiologie dans ses aspects fondamentaux médicaux écologiques alimentaires et industriels voir la suite

microbiology lansing m prescott john p harley donald a klein - Aug 15 2023

web microbiology lansing m prescott john p harley donald a klein mcgraw hill higher education 2005 science 1130 pages

prescott harley and klein s 6th edition provides a

prescott harley and klein s microbiology willey joanne m - Apr 11 2023

web this edition of microbiology provides a balanced comprehensive introduction to all major areas of microbiology the text is appropriate for students preparing for careers in medicine dentistry nursing and allied health as well as research teaching and industry

microbiología prescott harley y klein universitat autònoma - Dec 27 2021

web t1 microbiología prescott harley y klein a2 gibert gonzalez isidre n1 traducido de microbiology prescott harley y klein 01 febrero 2008 mcgraw hill py 2009 1 1 y1 2009 1 1 m3 traducción vl 1 bt microbiología prescott harley y klein er

microbiologie lansing m prescott john p harley donald a klein - Sep 04 2022

web microbiologie lansing m prescott john p harley donald a klein de boeck 2003 microbiology 1137 pages après un rappel historique de sa découverte et de son évolution la

prescott harley klein s microbiology by joanne willey goodreads - Mar 30 2022

web jan 10 2007 the brand new author team of prescott harley and klein s microbiology continues the tradition of past editions by providing a balanced comprehensive introduction to all major areas of microbiology because of this balance the seventh edition of microbiology is appropriate for microbiology majors and mixed majors courses

prescott harley klein s microbiology amazon co uk - Jun 01 2022

web the brand new author team of prescott harley and klein s microbiology continues the tradition of past editions by providing a balanced comprehensive introduction to all major areas of microbiology because of this balance the seventh edition of microbiology is appropriate for microbiology majors and mixed majors courses