

# **BTR 93LE 97LE AUTO TRANSMISSION**

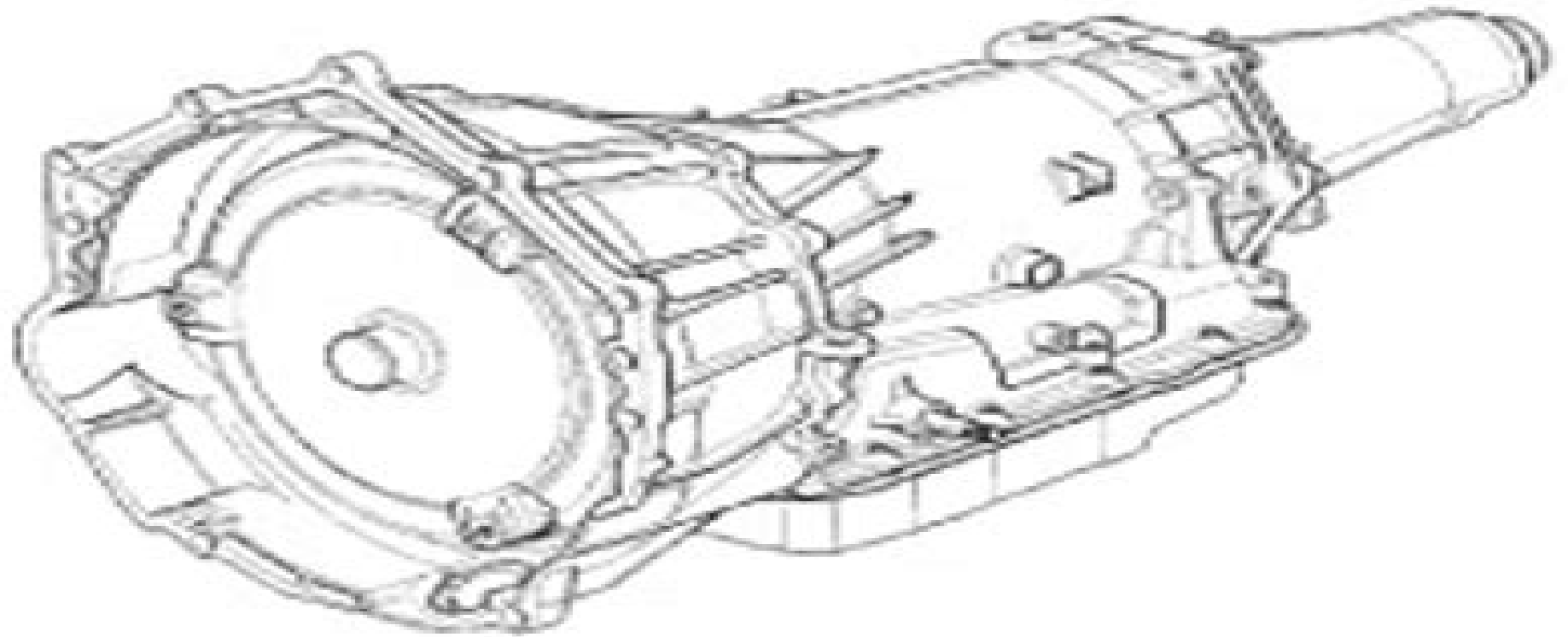

## **WORKSHOP SERVICE MANUAL**

# Btr Transmission Manual

**Ian Pickup**



## **Btr Transmission Manual:**

NATO and Warsaw Pact Armoured Fighting Vehicles of the Cold War Michael Green, 2025-08-05 This authoritative and superbly illustrated book covers the full range of AFVs in service with NATO and WP armies over the four decades of the Cold War While tanks were the most recognized armored vehicles during the Cold War NATO and Warsaw Pact WP armies fielded a wide array of armored fighting vehicles AFVs These included armored cars armored personnel carriers APCs anti aircraft vehicles and self propelled artillery Over the Cold War years nations both progressively developed series of AFVs and introduced entirely new ranges APCs vital to all frontline units evolved from machine gun armed battlefield taxis such as the US M113 and Soviet BTR 60 series into sophisticated infantry fighting vehicles The Soviet BMP 1 US Bradley M2 M3 West German Marder and British Warrior and CVR series were classic examples of the latter with numerous variants The Soviet BRDM 2 series was the most numerous armored car The British Army fielded the Saladin Ferret and Fox and the German Army introduced the eight wheeled Luchs and tracked SPZ11 2 Kurz Early anti aircraft vehicles such as the American M42 with two 40mm Bofors were superseded by the formidable Soviet ZSU 23 4 Shilka and the West German Gepard with radar guided guns This authoritative and superbly illustrated book covers the full range of AFVs in service with NATO and WP armies over the four decades of the Cold War It will be an invaluable addition to the libraries of the expert and layman alike

*Jane's Armour and Artillery*, 2002      **Weapons and Tactics of the Soviet Army** David C. Isby, 1981      **Jane's Weapon Systems**, 1979      Moody's International Manual, 1996      **Air Force Manual** United States. Department of the Air Force, 1973      Official Gazette of the United States Patent and Trademark Office, 1995      *Armor*, 1982 The magazine of mobile warfare      *Poor's Manual of Public Utilities*, 1913      **Poor's Manual of Public Utilities; Street, Railway, Gas, Electric, Water, Power, Telephone and Telegraph Companies**, 1913

Right here, we have countless books **Btr Transmission Manual** and collections to check out. We additionally provide variant types and moreover type of the books to browse. The adequate book, fiction, history, novel, scientific research, as with ease as various extra sorts of books are readily nearby here.

As this Btr Transmission Manual, it ends up swine one of the favored book Btr Transmission Manual collections that we have. This is why you remain in the best website to see the unbelievable ebook to have.

<https://stats.tinkerine.com/data/Resources/fetch.php/burning%20desire%20part%202%20dark%20kingsburning%20desire.pdf>

## **Table of Contents Btr Transmission Manual**

1. Understanding the eBook Btr Transmission Manual
  - The Rise of Digital Reading Btr Transmission Manual
  - Advantages of eBooks Over Traditional Books
2. Identifying Btr Transmission Manual
  - Exploring Different Genres
  - Considering Fiction vs. Non-Fiction
  - Determining Your Reading Goals
3. Choosing the Right eBook Platform
  - Popular eBook Platforms
  - Features to Look for in an Btr Transmission Manual
  - User-Friendly Interface
4. Exploring eBook Recommendations from Btr Transmission Manual
  - Personalized Recommendations
  - Btr Transmission Manual User Reviews and Ratings
  - Btr Transmission Manual and Bestseller Lists
5. Accessing Btr Transmission Manual Free and Paid eBooks

- Btr Transmission Manual Public Domain eBooks
- Btr Transmission Manual eBook Subscription Services
- Btr Transmission Manual Budget-Friendly Options
- 6. Navigating Btr Transmission Manual eBook Formats
  - ePub, PDF, MOBI, and More
  - Btr Transmission Manual Compatibility with Devices
  - Btr Transmission Manual Enhanced eBook Features
- 7. Enhancing Your Reading Experience
  - Adjustable Fonts and Text Sizes of Btr Transmission Manual
  - Highlighting and Note-Taking Btr Transmission Manual
  - Interactive Elements Btr Transmission Manual
- 8. Staying Engaged with Btr Transmission Manual
  - Joining Online Reading Communities
  - Participating in Virtual Book Clubs
  - Following Authors and Publishers Btr Transmission Manual
- 9. Balancing eBooks and Physical Books Btr Transmission Manual
  - Benefits of a Digital Library
  - Creating a Diverse Reading Collection Btr Transmission Manual
- 10. Overcoming Reading Challenges
  - Dealing with Digital Eye Strain
  - Minimizing Distractions
  - Managing Screen Time
- 11. Cultivating a Reading Routine Btr Transmission Manual
  - Setting Reading Goals Btr Transmission Manual
  - Carving Out Dedicated Reading Time
- 12. Sourcing Reliable Information of Btr Transmission Manual
  - Fact-Checking eBook Content of Btr Transmission Manual
  - Distinguishing Credible Sources
- 13. Promoting Lifelong Learning
  - Utilizing eBooks for Skill Development

- Exploring Educational eBooks
14. Embracing eBook Trends
- Integration of Multimedia Elements
  - Interactive and Gamified eBooks

### **Btr Transmission Manual Introduction**

Free PDF Books and Manuals for Download: Unlocking Knowledge at Your Fingertips In today's fast-paced digital age, obtaining valuable knowledge has become easier than ever. Thanks to the internet, a vast array of books and manuals are now available for free download in PDF format. Whether you are a student, professional, or simply an avid reader, this treasure trove of downloadable resources offers a wealth of information, conveniently accessible anytime, anywhere. The advent of online libraries and platforms dedicated to sharing knowledge has revolutionized the way we consume information. No longer confined to physical libraries or bookstores, readers can now access an extensive collection of digital books and manuals with just a few clicks. These resources, available in PDF, Microsoft Word, and PowerPoint formats, cater to a wide range of interests, including literature, technology, science, history, and much more. One notable platform where you can explore and download free Btr Transmission Manual PDF books and manuals is the internet's largest free library. Hosted online, this catalog compiles a vast assortment of documents, making it a veritable goldmine of knowledge. With its easy-to-use website interface and customizable PDF generator, this platform offers a user-friendly experience, allowing individuals to effortlessly navigate and access the information they seek. The availability of free PDF books and manuals on this platform demonstrates its commitment to democratizing education and empowering individuals with the tools needed to succeed in their chosen fields. It allows anyone, regardless of their background or financial limitations, to expand their horizons and gain insights from experts in various disciplines. One of the most significant advantages of downloading PDF books and manuals lies in their portability. Unlike physical copies, digital books can be stored and carried on a single device, such as a tablet or smartphone, saving valuable space and weight. This convenience makes it possible for readers to have their entire library at their fingertips, whether they are commuting, traveling, or simply enjoying a lazy afternoon at home. Additionally, digital files are easily searchable, enabling readers to locate specific information within seconds. With a few keystrokes, users can search for keywords, topics, or phrases, making research and finding relevant information a breeze. This efficiency saves time and effort, streamlining the learning process and allowing individuals to focus on extracting the information they need. Furthermore, the availability of free PDF books and manuals fosters a culture of continuous learning. By removing financial barriers, more people can access educational resources and pursue lifelong learning, contributing to personal growth and professional development. This democratization of knowledge promotes intellectual curiosity and empowers

individuals to become lifelong learners, promoting progress and innovation in various fields. It is worth noting that while accessing free Btr Transmission Manual PDF books and manuals is convenient and cost-effective, it is vital to respect copyright laws and intellectual property rights. Platforms offering free downloads often operate within legal boundaries, ensuring that the materials they provide are either in the public domain or authorized for distribution. By adhering to copyright laws, users can enjoy the benefits of free access to knowledge while supporting the authors and publishers who make these resources available. In conclusion, the availability of Btr Transmission Manual free PDF books and manuals for download has revolutionized the way we access and consume knowledge. With just a few clicks, individuals can explore a vast collection of resources across different disciplines, all free of charge. This accessibility empowers individuals to become lifelong learners, contributing to personal growth, professional development, and the advancement of society as a whole. So why not unlock a world of knowledge today? Start exploring the vast sea of free PDF books and manuals waiting to be discovered right at your fingertips.

### **FAQs About Btr Transmission Manual Books**

1. Where can I buy Btr Transmission Manual books? Bookstores: Physical bookstores like Barnes & Noble, Waterstones, and independent local stores. Online Retailers: Amazon, Book Depository, and various online bookstores offer a wide range of books in physical and digital formats.
2. What are the different book formats available? Hardcover: Sturdy and durable, usually more expensive. Paperback: Cheaper, lighter, and more portable than hardcovers. E-books: Digital books available for e-readers like Kindle or software like Apple Books, Kindle, and Google Play Books.
3. How do I choose a Btr Transmission Manual book to read? Genres: Consider the genre you enjoy (fiction, non-fiction, mystery, sci-fi, etc.). Recommendations: Ask friends, join book clubs, or explore online reviews and recommendations. Author: If you like a particular author, you might enjoy more of their work.
4. How do I take care of Btr Transmission Manual books? Storage: Keep them away from direct sunlight and in a dry environment. Handling: Avoid folding pages, use bookmarks, and handle them with clean hands. Cleaning: Gently dust the covers and pages occasionally.
5. Can I borrow books without buying them? Public Libraries: Local libraries offer a wide range of books for borrowing. Book Swaps: Community book exchanges or online platforms where people exchange books.
6. How can I track my reading progress or manage my book collection? Book Tracking Apps: Goodreads, LibraryThing,

and Book Catalogue are popular apps for tracking your reading progress and managing book collections. Spreadsheets: You can create your own spreadsheet to track books read, ratings, and other details.

7. What are Btr Transmission Manual audiobooks, and where can I find them? Audiobooks: Audio recordings of books, perfect for listening while commuting or multitasking. Platforms: Audible, LibriVox, and Google Play Books offer a wide selection of audiobooks.
8. How do I support authors or the book industry? Buy Books: Purchase books from authors or independent bookstores. Reviews: Leave reviews on platforms like Goodreads or Amazon. Promotion: Share your favorite books on social media or recommend them to friends.
9. Are there book clubs or reading communities I can join? Local Clubs: Check for local book clubs in libraries or community centers. Online Communities: Platforms like Goodreads have virtual book clubs and discussion groups.
10. Can I read Btr Transmission Manual books for free? Public Domain Books: Many classic books are available for free as they're in the public domain. Free E-books: Some websites offer free e-books legally, like Project Gutenberg or Open Library.

### **Find Btr Transmission Manual :**

~~burning desire part 2 dark kings~~  
~~burning desire~~

~~buried alive how 33 miners survived 69 days deep under the chilean desert~~

~~built to survive hiv wellness guide fourth edition~~

~~burns phonic shorthand 1873 phonography~~

~~business law study guide 9th edition answers~~

~~business informative speech with presentation aids~~

~~burger king glassdoor~~

~~busca tu elemento gestion del conocimiento or knowledge management spanish edition~~

**bulk mining explosives zambia**

burn math class

**bushwackers dance lessons**

burger king new kent va

burger king guru knowledge center

**burning lust an mmf bisexual threesome**



[business contact manager user guide](#)

**Btr Transmission Manual :**

**vermeer parts equipment manuals request today** - Oct 07 2023

web see detailed specifications and technical data for vermeer bc 1250 a manufactured in 1998 2001 get more in depth insight with vermeer bc 1250 a specifications on lectura

**vermeer 1250 wood chippers logging equipment auction** - Apr 01 2023

web see detailed specifications and technical data for wood chippers get more in depth insight on vermeer wood chippers and find specific machine specifications on

[vermeer wood chippers specifications datasheets](#) - Jan 30 2023

web find vermeer 1250 and other wood chippers for sale on machinio

**vermeer bc1200xl wood chipper with gas engine for** - Dec 17 2021

**shop our selection of vermeer 1250 parts and manuals jensales** - Jul 04 2023

web view and download vermeer bc1200xl operator s manual online brush chipper bc1200xl chipper pdf manual download *vermeer bc1250 construction equipment for sale* - Apr 20 2022

**vermeer 1250 chippers arborist chainsaw tree work forum** - Feb 28 2023

web oct 27 2022 vermeer 1250 12 wood tree chipper original a new operator s manual for a vermeer 606 brush chipper 1995 vermeer 1250 wood chipper for sale in

[vermeer 1250 wood chippers forestry equipment auction](#) - Feb 16 2022

*vermeer bc1000xl maintenance manual pdf* - May 02 2023

web nov 28 2010 i had a 1250 didnt like it that much large chunks always found thier way behind the left feed roller had to shut down and get it out all the time because if you

**vermeer 1250 construction equipment for sale marketbook** - Mar 20 2022

[vermeer bc 1250 a specifications technical data](#) - Sep 06 2023

web nov 9 2006 nov 6 2006 1 just bought a used vermeer 1250 chipper and would like to find a source for the operators parts manual i believe it has the perkins 4 236 diesel

**vermeer 1250bc towable wood chippers logging equipment** - May 22 2022

web sep 21 2022 the vermeer bc1200xl brush chipper with a gas engine was built tough to help you clear brush from your jobsites at any scale learn more about this wood chipper

**vermeer 1250 auction results 27 listings** - Jul 24 2022

web online auction view details 23 4 updated tuesday april 11 2023 08 42 am 1995 vermeer 1250 towable wood chippers forestry equipment sold price usd

vermeer 1250 wood chipper manual canada guide step by - Sep 25 2022

web oct 18 2023 vermeer bc1250 with only 1658 hours 12 capacity self feeding disk style chipper is powered by an 84hp perkins diesel engine also has the curbside

**looking for vermeer 1250 operators manual arborist chainsaw** - Aug 05 2023

web some of the parts available for your vermeer 1250 include engine and overhaul kits

demo video how to operate a vermeer 12 tree chipper - Jun 22 2022

web oct 18 2023 view details 12 updated friday november 03 2023 09 24 am vermeer 1250bc towable wood chippers forestry equipment auction date november 16

**vermeer 1250 construction equipment for sale** - Jan 18 2022

no results for vermeer 1250 wood chippers machinio - Aug 25 2022

web bc1250a wood chippers towable 12 capacity self feeding disk style chipper is powered by an 84hp perkins diesel engine also has the curbside rotating chipper

vermeer bc1200xl operator s manual pdf - Jun 03 2023

web apr 26 2022 view details 23 4 updated tuesday april 11 2023 08 42 am lot 4432 1995 vermeer 1250 towable wood chippers sold price log in to see more details

parts for vermeer agricultural and industrial equipment - Oct 27 2022

web browse a wide selection of new and used vermeer 1250bc towable wood chippers logging equipment auction results near you at forestrytrader com

**vermeer brush wood chippers tree care** - Nov 27 2022

web jul 23 2020 turn a bundle of tree branches to mulch in a hurry with a vermeer 12 tree chipper rental in this 7 minute video anthony demonstrates the basic operation o

parts accessories for vermeer stump grinders - Dec 29 2022

web vermeer 1250 towable wood chipper diesel manual spout controls hyd swing pintle hitch tail lights clean municipal

machine starts runs operates no title

[balakumaran author of ஶஶ ஶஶ ஶஶ 1](#) - Nov 06 2022

web jun 25 2023 balakumaran novel gankaikonda cholapuram free download 2 8 downloaded from uniport edu ng on june 25 2023 by guest can love happen twice

**balakumaran novels tamil pdf world** - Jun 13 2023

web gangai konda chozhan part 2 tamilnannool com pdf free download as pdf file pdf or view presentation slides online

[balakumaran books goodreads](#) - Jan 08 2023

web jun 19 2023 balakumaran novel gankaikonda cholapuram free download 1 8 downloaded from uniport edu ng on june 19 2023 by guest balakumaran novel

*gangaikonda cholapuram varalaru department of archaeology* - Dec 27 2021

[balakumaran novels free pdf download hsslive](#) - Oct 05 2022

web gangai konda chozhan authored by balakumaran is a historical novel about the novels free download tamil novels pdf gangai konda cholapuram pdf

**balakumaran novel gankaikonda cholapuram free download** - Aug 03 2022

web with this balakumaran novel gankaikonda cholapuram free download but end happening in harmful downloads rather than enjoying a good book similar to a mug of

**gangai konda chozhan part 2 pdf pdf scribd** - Mar 10 2023

web aug 4 2021 but we have also provided the balakumaran novels free download in pdf format for you guys and girls who cannot buy this novel how to download

**download novel gankaikonda cholapuram balakumaran free** - Mar 30 2022

web jul 20 2023 this balakumaran novel gankaikonda cholapuram free download as one of the most energetic sellers here will extremely be along with the best options to review

[ஶஶ ஶஶ ஶஶ 4](#) - Jul 14 2023

web 58 rows mar 5 2020 balakumaran novels free download pdf balakumaran

[download cholapuram novel gankaikonda free balakumaran](#) - Jul 02 2022

web may 6 2023 balakumaran novel gankaikonda cholapuram free download 1 1 downloaded from uniport edu ng on may 6 2023 by guest balakumaran novel

**gangaikondacholapuram nagaswamy r free download** - Nov 25 2021

*gangai konda chozhan part 1 is waiting to be* - Dec 07 2022

web download cholapuram novel gankaikonda free balakumaran is obtainable in our book compilation an online access to it is set as public so you can get it immediately

**balakumaran novel gankaikonda cholapuram free download pdf** - Sep 04 2022

web download novel gankaikonda cholapuram balakumaran free by online we reward for you this appropriate as skillfully as basic airs to fetch those all read the download

*100 best balakumaran books novels pdf free download* - Aug 15 2023

web balakumaran balakumaran books pdf are available here you can download all balakumaran novels from here for free enakkul pesugiren by balakumaran kai

[2 gangai konda](#) - Feb 09 2023

web jun 8 2023 balakumaran novel gankaikonda cholapuram free download pdf is available in our digital library an online access to it is set as public so you can download

*gangai konda chozhan part 1 by balakumaran* - May 12 2023

web jan 1 2019 story of one of the greatest thamizh emperors viz rajendra cholana told in his inimitable style by balakumaran balakumaran is a genius and i am yet to read any

[balakumaran novel gankaikonda cholapuram free download](#) - Jun 01 2022

web may 6 2021 gangaikonda cholapuram varalaru addeddate 2021 05 06 06 26 27 identifier gangaikonda cholapuram varalaru identifier ark ark 13960 t0zq4wm40

**balakumaran novels free download pdf read online** - Apr 11 2023

web avg rating 4 09 140 ratings published 2001 want to read rate this book 1 of 5 stars 2 of 5 stars 3 of 5 stars 4 of 5 stars 5 of 5 stars [6 udaiyar](#)

[balakumaran novel gankaikonda cholapuram free download](#) - Oct 25 2021

[gangai konda cholana novel pdf free download orexevas](#) - Apr 30 2022

web nov 5 2017 book from the archaeological survey of india central archaeological library new delhi book number 57366 book title gangaikondacholapuram book author

[balakumaran novel gankaikonda cholapuram free download](#) - Jan 28 2022

**balakumaran novel gankaikonda cholapuram free download** - Feb 26 2022

web we meet the expense of balakumaran novel gankaikonda cholapuram free download pdf and numerous book collections

from fictions to scientific research in any way in the  
**balakumaran novel gankaikonda cholapuram free download** - Sep 23 2021

**us history staar answer key answers for 2023 exams** - Jun 01 2022

web oct 24 2020 9607 pdf staar u s history answer key paper 2021 release staar u s history answer key paper 2021 release  
created date 10 24 2020 9 22 01 am tea texas gov sites default files staar 2021 key eoc ush tagged pdf staar u s history  
answer key mylibrary org

*staar u s history test prep practice study com* - Nov 06 2022

web practice test staar us history historical eras significant events 1877 to present ch 3 staar us history political economic  
social change 1877 1898

**8th grade u s history staar study packet pdfiller** - Mar 30 2022

web comments and help with 8th grade us history staar study packet answer key assignment 2 seventy seven trade partners  
are the countries and or regions where the colony imported a specified product in the year of the colonist s birth

**free study guide for the staar test updated 2023 union** - Apr 11 2023

web in this study guide we ve outlined what you should know before taking the staar u s history test for high school don t  
forget to access our practice questions and flashcards to round out your review and to consult additional resources and  
maybe your old textbook for further info on things you don t remember as well as you thought you

*get 8th grade us history staar study packet us legal forms* - Dec 27 2021

web follow the simple instructions below are you looking for a fast and efficient tool to fill out 8th grade us history staar  
study packet at a reasonable price our platform provides you with a wide selection of templates that are offered for

*mrs phillip s 8th grade u s history class staar review* - Oct 05 2022

web everything is in chronological order it is the most important information in each unit and key words have been  
highlighted the crossword puzzle answer keys have been placed the folders with the previous staar questions for each era  
and the 8th grade review packet answer key has been uploaded below

staar resources mrs bounds class 8th grade u s history - Feb 09 2023

web u s history baines middle school website resources staar study packet staar study packet 2013 2 doc staar review packet  
answers and staar pre assessment packet answers staar study packet answers doc

**staar 8th grade us history complete review packet with key** - Sep 04 2022

web mar 7 2022 then use the answers to play head of class trashketball swat it or other review games teks are listed next to  
each content grouping of questions along with whether the tek is a readiness or supporting standard

**8th grade u s history staar teaching resources tpt** - Feb 26 2022

web this comprehensive packet has you covered for 18 days of review for the 8th grade u s history staar test or with some slight modifications can align with the common core curriculum for any 8th grade u s history end of year assessment

staar u s history test prep practice final exam study com - Jul 02 2022

web staar u s history test prep practice final exam choose your answer to the question and click continue to see how you did then click next question to answer the next question when you

staar u s history answer key paper 2021 release - Jul 14 2023

web answer key paper 2021 release item number reporting category readiness or supporting content student expectation process student expectation correct answer 1

**u s history practice assessment texas education agency** - Dec 07 2022

web u s history page 4 directions read each question carefully choose the best answer to each question for open response questions determine the best answer to the question 1 this time line is about the national motto of the united states why did federal leaders have a renewed interest in the phrase in god we trust a

8th grade - Jun 13 2023

web staar study packet answer guide name history teacher complete the activities using your staar review sheet once you finish an assignment check your answers by using the answer key provided for some not all assignments and or your taks review sheet thirteen original colonies

staar answer packet doc 8th grade u s history staar study packet - Aug 03 2022

web 8th grade u s history staar study packet name answer key history teacher complete the activities using your staar review sheet once you finish an assignment check your answers by using the answer key provided for some not all assignments and or your taks review sheet

results for us history staar packet tpt - Apr 30 2022

web histoteam this editable powerpoint and editable review packet serve as a comprehensive review to prepare for the texas staar exam 8th grade u s history exploration through reconstruction the powerpoint 145 slides serves as the guide and answer key to fill in the packet 25 pages

staar study packet answers 8th grade u s history staar - May 12 2023

web view staar study packet answers from math algebra at sharpstown h s 8th grade u s history staar study packet answer guide name history teacher complete the activities using your staar review

**staar us history practice test questions test prep review** - Jan 08 2023

web staar us history test practice questions test preparation help and eoc review questions study guide and flashcards

8th grade us history staar study packet form signnow - Jan 28 2022

web the question arises how can i design the 8th grade us history star study packet form i received right from my gmail without any third party platforms the answer is simple use the signnow chrome extension below are five simple steps to get your 8th grade us history star study packet form designed without leaving your gmail account

*staar review answer key studylib net* - Aug 15 2023

web 3 populism popular sovereignty people participate in political life people rule 4 egalitarianism 2 individualism free to choose little to no government control laissez faire free enterprise equality society where people are equal land ownership social equals alexis de tocqueville said these values are crucial to america

**u s history staar test study guide flashcards quizlet** - Mar 10 2023

web study with quizlet and memorize flashcards containing terms like this was the year jamestown the first colony was founded this was the year the mayflower compact was created this was the year the declaration of independence was signed and more